

User Guide

AM610-CPU1608TP CPU Module

19010675
A01

1

Thank you for purchasing the AM610-CPU1608TP CPU communication module developed and manufactured independently by Inovance.

AM610 series PLC is a medium-sized PLC developed based on CoDeSys. It fully supports the IEC61131-3 programming system. The AM610-CPU1608TP module supports PROFIBUS-DP, Modbus/TCP, and Modbus (serial port), and unique high-speed I/O interfaces, to meet the needs of high-speed applications.

This guide describes the specifications, characteristics, and using methods of the AM610-CPU1608TP CPU module. Please read this guide carefully before using to ensure more safe usage. Please refer to the AM600 Series PLC Hardware Manual and the AM600 Series PLC Programming Manual to understand the use of the user program development environment and design method of the user program of the product. You can download the latest materials from www.inovance.com

1. Safety Precautions

Safety information and precautions are identified into two grades: Warning and Caution. Please make sure to operate properly with adequate safety assurance.

- WARNING** Indicates the improper operation which, if not avoided, may cause death or serious injury.
- CAUTION** Indicates the improper operation which, if not avoided, may cause moderate or minor injury, as well as equipment damage.

In some cases, even failure to follow "Cautions" may also lead to serious consequences. Please make sure to follow both warnings and cautions, otherwise, it may cause death or serious injury, as well as product and relevant equipment and system damage. Please keep this guide well so that it can be read when necessary and forward this guide to the end user.

During control system design

- WARNING**
 - Provide a safety circuit outside the PLC so that the control system can still work safely once external power failure or PLC fault occurs.
 - Add a fuse or circuit breaker because the module may smoke or catch fire due to long-time overcurrent caused by operation above rated current or load short-circuit.
- CAUTION**
 - An emergency stop circuit, a protection circuit, a forward/reverse operation interlocked circuit, and a upper position limit and lower position limit interlocked circuit must be set in the external circuits of the PLC to prevent damage to the machine.
 - To ensure safe operation, for output signals related to critical accidents, please design external protection circuit and safety mechanism;
 - Once the PLC CPU detects abnormality in the system, all outputs may be closed; however, when a fault occurs in the controller circuit, the output may not be under control. Therefore, it is necessary to design an appropriate external control circuit to ensure normal operation;
 - If the PLC's output units such as relays or transistors are damaged, the output may fail to switch between ON and OFF states according to the commands;
 - The PLC is designed to be used in indoor electrical environment (overvoltage category II). The power supply must have a system-level lightning protection device, assuring that overvoltage due to lightning shock can't be applied to the PLC's power supply input terminals, signal input terminals and output terminals and so forth, so as to avoid damage to the equipment.

During installation

- WARNING**
 - Installation must be carried out by the specialists who have received the necessary electrical training and understood enough electrical knowledge.
 - Disconnect all external power supplies of the system before module assembly/disassembly and wiring. Failure to do so may result in electric shock, module fault or malfunction.
 - Do not use the PLC where there are dust, oil smoke, conductive dust, corrosive or combustible gases, or exposed to high temperature, condensation, wind & rain, or subject to vibration and impact. Electric shock, fire and malfunction may also result in damage or deterioration to the product.
 - The PLC is an open-type device that must be installed in a control cabinet with lock (cabinet housing must satisfy protection of over IP20). Only the personnel who have the necessary electrical training and experience can open the cabinet.

- CAUTION**
 - Prevent metal filings and wire ends from dropping into ventilation holes of the PLC during installation. Failure to do so may result in fire, fault and malfunction.
 - Ensure there are no foreign matters on the ventilation surface. Failure to comply may result in poor ventilation, which may cause fire, fault and malfunction.
 - Ensure the module is connected to the respective connector securely and hook the module firmly. Improper installation may result in malfunction, fault or fall-off.

During wiring

- WARNING**
 - Wiring must be carried out by personnel who have the necessary electrical training and experience.
 - Disconnect all external power supplies of the system before wiring. Failure to comply may result in electric shock, module fault or malfunction.
 - Install the terminal cover attached to the product before power-on or operation after wiring is completed. Failure to comply may result in electric shock.
 - Perform good insulation on terminals so that insulation distance between cables will not reduce after cables are connected to terminals. Failure to comply may result in electric shock or damage to the equipment.

- CAUTION**
 - Prevent metal filings and wire ends from dropping into ventilation holes of the PLC at wiring. Failure to comply may result in fire, fault and malfunction.
 - The external wiring specification and installation method must comply with local regulations. For details, see the wiring section in this guide.
 - To ensure safety of equipment and operator, use cables with sufficient diameter and connect the cables to ground reliably.
 - Wire the module correctly after making clear of the connector type. Failure to comply may result in module and external equipment fault.
 - Tighten bolts on the terminal block in the specified torque range. If the terminal is not tight, short-circuit, fire or malfunction may be caused. If the terminal is too tight, fall-off, short-circuit, fire or malfunction may be caused.
 - If the connector is used to connect with external equipment, perform correct crimping or welding with the tool specified by manufacturer. If connection is in poor contact, short-circuit, fire or malfunction may be caused.
 - A label on the top of the module is to prevent foreign matters entering the module. Do not remove the label during wiring. Remember to remove it before system operation, facilitating ventilation.
 - Do not bundle control wires, communication wires and power cables together. They must be run with distance of more than 100 mm. Otherwise, noise may result in malfunction.
 - Select shielded cable for high-frequency signal input/output in applications with serious interference so as to enhance system anti-interference ability.

During maintenance & inspection

- WARNING**
 - Maintenance & inspection must be carried out by personnel who have the necessary electrical training and experience.
 - Do not touch the terminals while the power is on. Failure to comply may result in electric shock or malfunction.
 - Disconnect all external power supplies of the system before cleaning the module or re-tightening screws on the terminal block or screws of the connector. Failure to comply may result in electric shock.
 - Disconnect all external power supplies of the system before removing the module or connecting/removing the communication wirings. Failure to comply may result in electric shock or malfunction.

- CAUTION**
 - Get acquainted with the guide and ensure safety before online modification, forcible output, and RUN/STOP operation.
 - Disconnect the power supply before installing/removing the extension card.

At disposal

- CAUTION**
 - Treat scrapped module as industrial waste. Dispose the battery according to local laws and regulations.

2. Product Information

Model and Nameplate

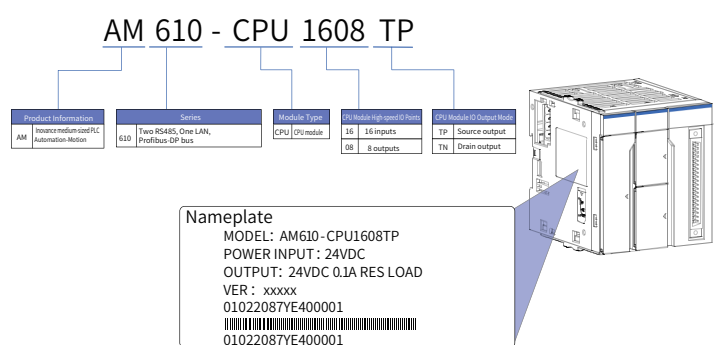

Figure 1 Description of model and nameplate

Model	Classification	Description	Applicable to
AM610-CPU1608TP	CPU module	4 M program storage space; 8 M data storage space Two RS485; Modbus/TCP; Modbus (serial port); One LAN; Supporting basic movement control functions; and supporting PROFIBUS-DP master station functions; Built-in 16-input 8-output high-speed I/O Source type output	AM610

External Interface

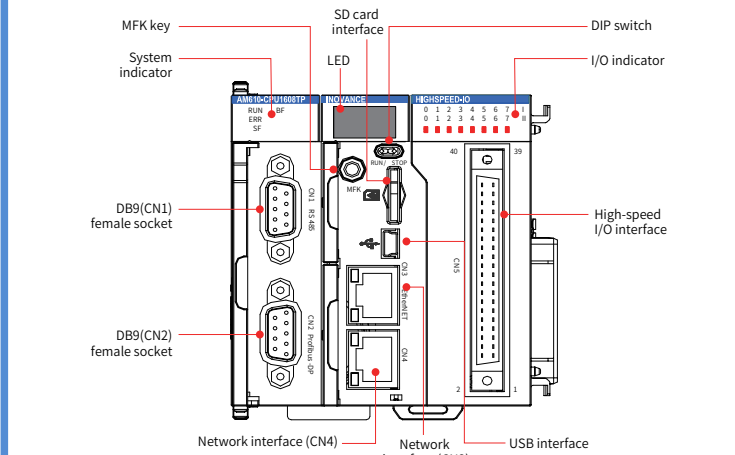

Figure 2 Diagram 1 of the CPU module interface

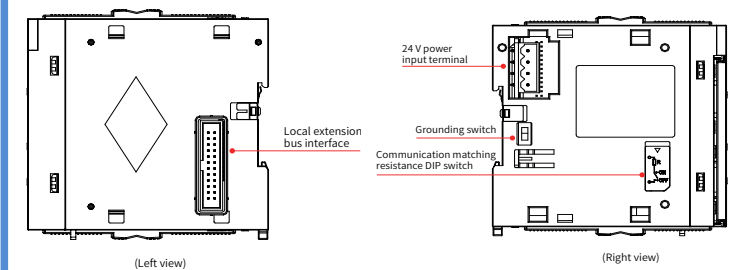
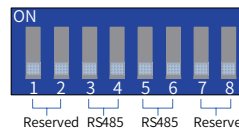

Figure 3 Diagram 2 of the CPU module interface

Interface Name	Function
DB9 (CN1)/(Female socket)	Two RS485 interfaces, supporting the MODBUS protocol
DB9 (CN2)/(Female socket)	PROFIBUS-DP protocol
Ethernet port (CN4)	None
Ethernet port (CN3)	1. MODBUS TCP 2. Standard Ethernet function 3. System program debugging 4. User program downloading and debugging (only supporting IPv4)
USB	Program downloading and debugging
High-speed I/O	16-point high-speed input 8-point high-speed output
I/O indicator	16-channel input and 8-channel output signal valid indicator
DIP switch	RUN/STOP DIP switch
SD card interface	Stores user programs and data
MFK key	MFK multi-function key
Indicators	Running indicator RUN CPU module running error indicator ERR System error indicator SF Communication error indicator BF
7-segment LED	Displays alarm messages and MFK key response prompt messages
Local expansion bus interface	Can expand up to 16 I/O modules. The actual number and configuration depend on each module's power consumption Not supporting hot plugging
24 V power input terminal	24 VDC voltage input. The AM600 power supply module must be used for power supply.
Grounding switch	Connection switch providing the system internal digital ground and housing ground. It is not connected by default. It is used only on special occasions where the system internal digital ground must be used as a reference plane. You shall not operate it without authorization; otherwise system stability is affected.
Communication matching resistance DIP switches	ON indicates matching resistance connection (all OFF by default). 3 and 4 are COM1 (RS485), 5 and 6 are COM0 (RS485), 1, 2, 7, and 8 are reserved:



General specifications

Item	Specifications					
Programming mode	IEC 61131-3 programming languages (LD, FBD, IL, ST, SFC, CFC)					
Program execution mode	Complied execution					
User program storage space	4 MBytes					
Flash save space upon power failure	512 KBytes					
SD memory card capacity	Up to 32 G general SD card					
Soft elements and characteristics	Element	Name	Quantity	Default	Storage Attributes	Description
	I	Input relay	64 KWords	Not save	No	X: 1-bit
	Q	Output relay	64 KWords	Not save	No	B: 8-bit
	M	Auxiliary relay	240 KWords	Save	-	D: 32-bit
	SM	Special mark	10000 bits	Save	Special use	L: 64-bit
	SD	Special registers	10000 Words	Save	Special use	Special registers
Program save mode upon power failure	Flash hold/SD card hold optional (No save upon power failure is performed if power failure occurs at power-on-time of shorter than 35s)					
Internal 5 V power output current	1,200 mA (rated value)					
Interrupt mode	8-point input interrupt (CPU module high-speed DI), supporting rising edge and falling edge interrupt.					

Input Specifications

Item	Specifications
Signal Name	High-speed input (differential or single-ended) (X0-X5) 24 V input 24 VDC (+20% to -15%, pulsation within 5%) 7.3 mA (typical) (at 24 VDC) More than 5 mA Less than 1.5 mA 3.3 kΩ 800 Kpps (two-phase quadruplicated frequency), 200 kHz (single-phase input) (40%:60%) to (60%:40%) Two groups of common terminals
Rated input voltage	24 VDC (+20% to -15%, pulsation within 5%)
Rated input current	7.3 mA (typical) (at 24 VDC)
ON current	More than 5 mA
OFF current	Less than 1.5 mA
Input resistance	3.3 kΩ
Maximum count speed	800 Kpps (two-phase quadruplicated frequency), 200 kHz (single-phase input)
Worst duty ratio at two-phase input	(40%:60%) to (60%:40%)
Common mode	Two groups of common terminals One common terminal per 10 points

Output Specifications

Item	Specifications
Signal Name	Output (Y0-Y7)
Output polarity	Source type output (high-side output)
Control circuit voltage	5 VDC to 24 VDC
Rated load current	0.1 A / point, 0.5 A / COM
Maximum voltage drop when the module is turned ON	0.2 V (typical value)
Leakage current when the module is turned OFF	Less than 0.1mA
Output frequency	200 kHz (You must connect an over 12 mA external equivalent load for 200 kHz output.)
Common mode	One common terminal per 4 points

The total extended distance of the high-speed I/O interface extension cable shall be within 3.0 m. The single-phase pulse duty ratio must be greater than 40% when high-speed input is in phases A and B.

3. Mechanical Design Reference

Dimensions

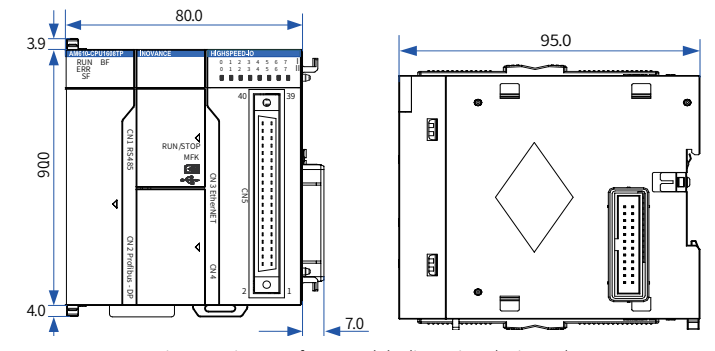
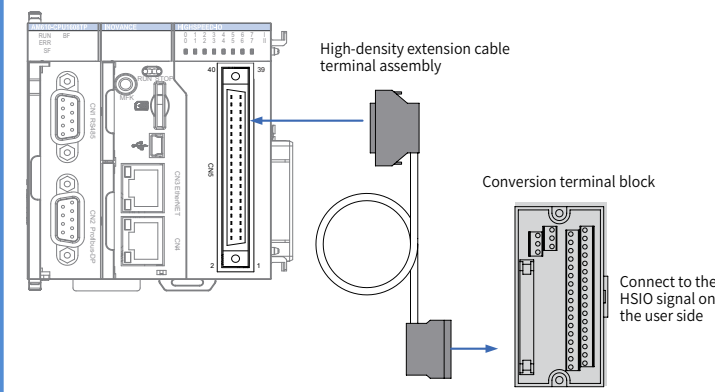

Figure 4 Diagram of CPU module dimensions (unit: mm)

4. Electrical Design Reference



Note: Inovance provides optional parts for this type of cable: code of the outer lead: 15300119; code of the conversion terminal block: 15020452.

Figure 5 Connection terminal arrangement of the CPU module

Classification	External Wiring	CNS Pin No.	Internal Circuit	Signal Name ²	
				Column B	Column A
Input	24 VDC	40	39	High-speed 24 V input (IN0-24V)	High-speed 24 V input (IN2-24V)
		38	37	High-speed differential input (IN0-DIFF)	High-speed differential input (IN2-DIFF)
		36	35	High-speed input common terminal (IN0-COM)	High-speed input common terminal (IN2-COM)
		34	33	High-speed 24 V input (IN1-24V)	High-speed 24 V input (IN3-24V)
		32	31	High-speed differential input (IN1-DIFF)	High-speed differential input (IN3-DIFF)
		30	29	High-speed input common terminal (IN1-COM)	High-speed input common terminal (IN3-COM)
		28	27	High-speed 24 V input (IN4-24V)	High-speed 24 V input (IN5-24V)
		26	25	High-speed differential input (IN4-DIFF)	High-speed differential input (IN5-DIFF)
		24	23	High-speed input common terminal (IN4-COM)	High-speed input common terminal (IN5-COM)
		22	21	Input common terminal (SS0)	Input common terminal (SS1)
Output	24 VDC	20	19	Standard input (IN6)	Standard input (IN7)
		18	17	Standard input (IN8)	Standard input (IN9)
		16	15	Standard input (IN4)	Standard input (IN8)
		14	13	Standard input (IN5)	Standard input (IN9)
		12	11	Standard input (LINE)	Standard input (LINE)
		10	9	Output (OUT0)	Output (OUT1)
		8	7	Output (OUT2)	Output (OUT3)
		6	5	Output (OUT4)	Output (OUT5)
		4	3	Output (OUT6)	Output (OUT7)
		2	1	Output common terminal (COM0)	Output common terminal (COM1)

¹ The defined numbers of the wiring terminals of a self-purchased high-density component may be different from the high-speed I/O port numbers of the AM600 CPU module. Pay attention to the mapping relationship between the numbers of the wiring terminals and the port numbers of the CPU module, to avoid misconnection.

² All 16 input channels of the CPU module support high-speed input. The first 6 input channels support 24 V single-ended or differential input. The last 10 input channels support 24 V single-ended input.

Wiring Precautions

- The total extended distance of the high-speed I/O interface extension cable shall be within 3.0 m.
- Do not bundle the extension cable together with power cables (high voltage, large current) which produce strong interference signals. Separate it from other cables and avoid cabling in parallel.
- Select recommended cables and pinboards for connection. It is recommended that shielded cables be used as extension cables to enhance immunity to interference.
- Ensure that the minimum bending radius of cables is greater than 76 mm when laying extension cables. In the case of 76 mm bending radius, malfunction may occur due to performance degradation and cable breaking.
- If an SIRON T024-K terminal block is used for interface wiring, see the following figure for the relation between the terminal names and the CNS pin numbers of the CPU module.

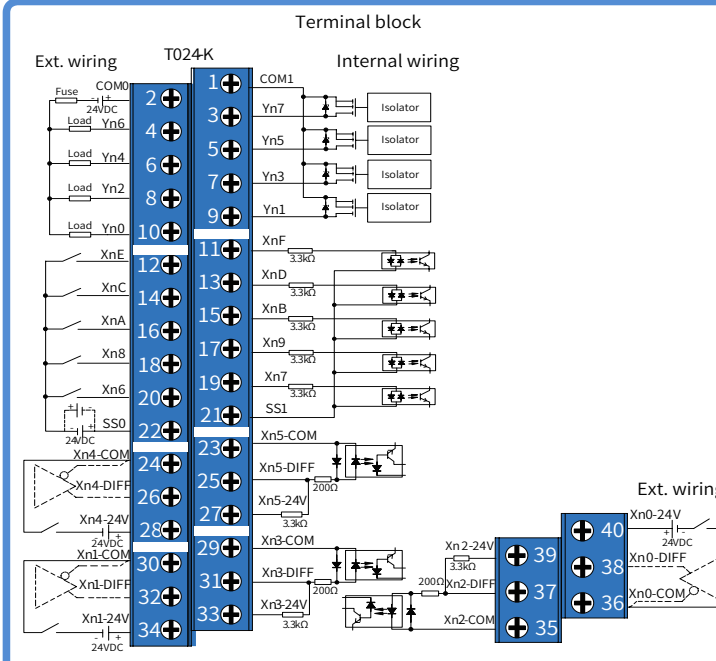

Figure 6 Connection of the terminal block

You can purchase the ① high-density extension cable, ② cable connector and ③ terminal block as shown in the figure above from Inovance. See the following for the details.

No.	Order No.	Type	Description
①	15300119	IO extension cable	40PIN FCN-MIL high-density extension cable (50 mm, with two 40PIN FCN connectors)
②	15050180	40PIN FCN connector	Users can use this connector to crimp a cable themselves.
③	15020452	IO extension card (16DI08DO)	40PIN MIL-screw terminal block

5. Communication Connection

Cabling of the CPU Module and Communication Module

- Connection of the DB9 connector
 - Plug the DB9 connector with wire into the DB9 plug on the module (pay attention to the connector orientation).
 - Tighten the screws on both sides of the DB9 connector.

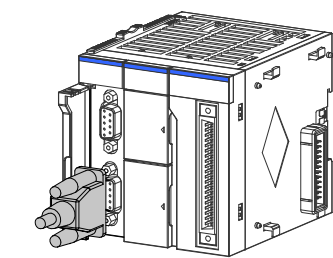

Figure 7 Diagram of DB9 connector connection

- Disassembly procedures: Loosen the screws on both sides of the DB9 connector, hold the plastic part of DB9, and pull out the connector along a horizontal direction.
- Connection of RJ45 network cable
 - Hold and insert the connector with cable into the RJ45 interface of the communication module until a clicking sound is made.

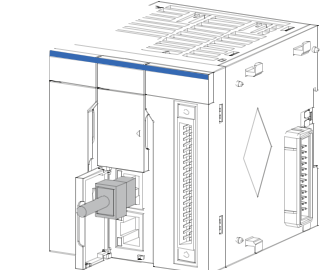

Figure 8 Diagram of network cable connection

- Requirements for securing communication cables
 - To avoid the influence on the communication cable due to other stresses and ensure the stability of communication, secure the cable near the equipment before PROFIBUS-DP wiring, as shown in the following figure:

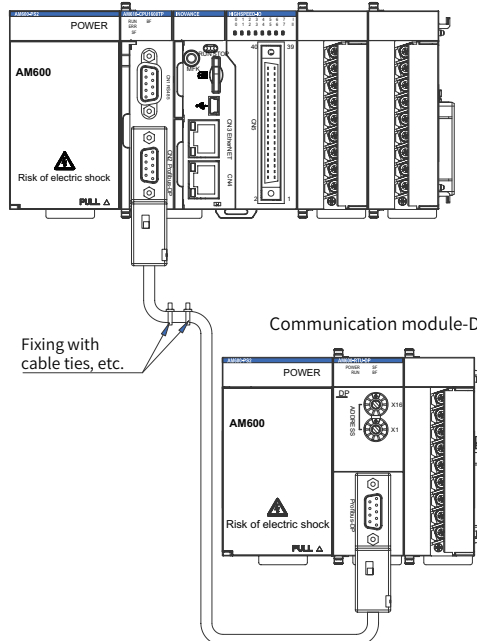

Figure 9 Necessary securing of communication cables near the equipment

Connection via PROFIBUS-DP bus

1) PROFIBUS-DP Bus Specifications

Item	Specifications
Protocol type	DPV0, and DPV1 (under development)
Number of slave stations	124 (A PROFIBUS-DP relay needs to be added for every 32 stations for extension.)
Communication speed	9.6 kbps, 19.2 kbps, 45.45 kbps, 93.75 kbps, 187.5 kbps, 500 kbps, 1.5 Mbps, 3 Mbps, 6 Mbps, or 12 Mbps
Communication data volume per slave station	244 Bytes/Slave
Total network communication data volume	5712 Bytes/Input; 5760 Bytes/Output
Basic functions	Initialization state, parameter configuration state, and data exchange state
Special functions	Diagnosis function. For details, see "Description of Indicators and MFK Key" below.
Error indicators	SF and BF. For details, see "Description of Indicators and MFK Key" below.

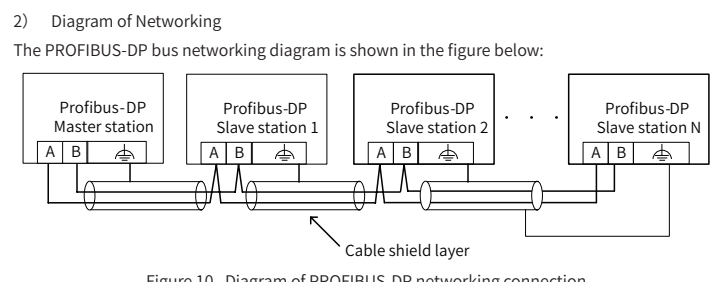

Figure 10 Diagram of PROFIBUS-DP networking connection

To ensure reliable connection of the PROFIBUS-DP bus, connect a terminal matching resistor at the terminal of the PROFIBUS-DP bus. You may select the terminal matching resistor by using the DIP switch according to the marking on the wiring terminal. Ensure that the cable shield layer and the system are reliably grounded.

The length of the PROFIBUS-DP bus communication cable varies according to the communication baud rate setting of the master station. The cable length needs to be restricted in strict accordance with the wiring standard. The transmission distance of the DP bus in the actual environment on-site can reach about 60% the theoretical value due to reasons such as on-site interference or cable errors.

The table below describes the baud rate and the cable length requirement.

Transmission Rate	Theoretical Transmission Length (m)	Actual Transmission Length (m)
9.6 to 93.75 Kbps	1000	600
187.5 Kbps	800	480
500 Kbps	400	320
1.5 Mbps	200	160
12 Mbps	100	60

Note: According to PROFIBUS-DP specifications, when there are more than 32 site devices on the network, or the network communication distance corresponding to a baud rate exceeds the specified range, relays need to be used to expand network connections.

3) Communication Interface Description

CN2 of the CPU module is a PROFIBUS-DP communication interface. The module uses a DB9 connector for data transfer.

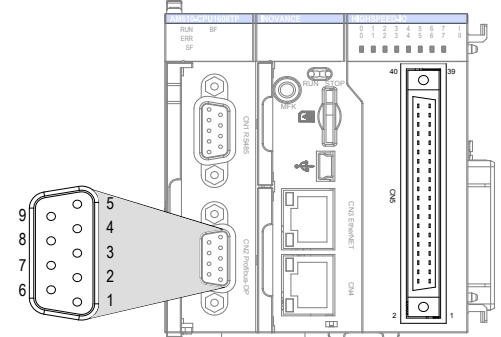

Figure 11 Definition of PROFIBUS-DP terminals on the CPU module

4) Wiring

PROFIBUS-DP uses a DB9 connector for output transfer. Below is the definition of DB9 pin signals:

Diagram	Terminal symbol	Terminal Name	Function
	1, 2, 7, 9	NC	Internal vacant
	3	Data cable B	Positive of data cable
	4	RTS	Request for transmitting signal
	5	GND	Isolated 5 V power ground
	6	+5 V	Isolated 5 V power supply
	8	Data cable A	Negative of data cable
	9	GND	Internal vacant
	5	RTS	Request for transmitting signal

The PROFIBUS-DP communication cable uses the DB9 connector (male connector), and is provided with a termination resistor. The appearance and the internal principle of the recommended terminal are shown in the figure below:

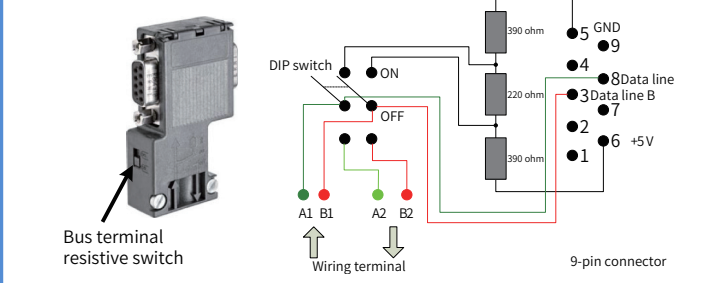

Figure 12 Diagram of the DB9 interface circuit

It is recommended that Siemens 6XV1830-0EH10 cables be used as the PROFIBUS-DP cables. If the bus connector is located at either terminal of the bus segment, a termination resistor must be used.

Location of the DIP switch	Description
ON	The termination resistor is connected.
OFF	The termination resistor is not connected.

Serial Communication Connection via RS485

Communication Interface Description

CN1 in the figure shows the RS485 interface. Two RS485 interfaces are supported. Two RS485 channels share the same DB9 interface, as shown in the following figure.

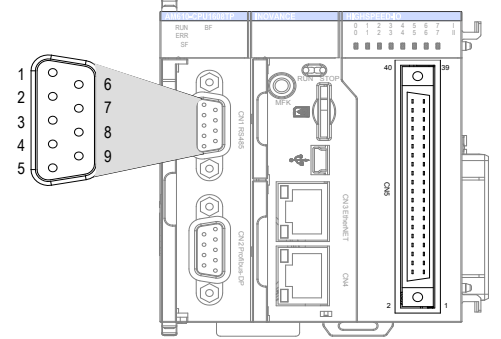

Figure 13 RS485 communication terminal definition on CPU module

Definition of DB9 assignment:

Channel	Pin	Definition	Function
COM0 (RS485)	1	RS485-	COM0 RS485 differential pair negative signal
	2	RS485+	COM0 RS485 differential pair positive signal
	5	GND0	COM0 power ground
COM1 (RS485)	6	RS485-	COM1 RS485 differential pair negative signal
	9	RS485+	COM1 RS485 differential pair positive signal
	3	GND1	COM1 power ground

Connection via Ethernet Monitoring

1) Diagram of Networking

The Ethernet interface of the CPU module can perform point-to-point connection to a computer, HMI, etc. using an Ethernet cable.

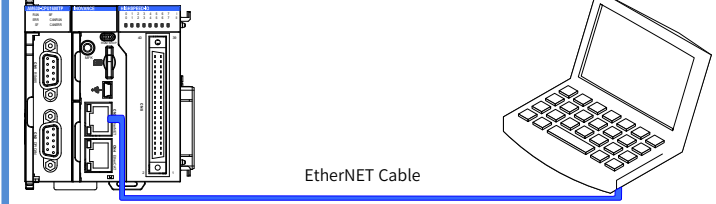

Figure 14 Connection of the CPU module to a PC

It can also be connected to a hub or switch using an Ethernet cable and then to other network equipment via the hub or switch to implement multi-point connection.

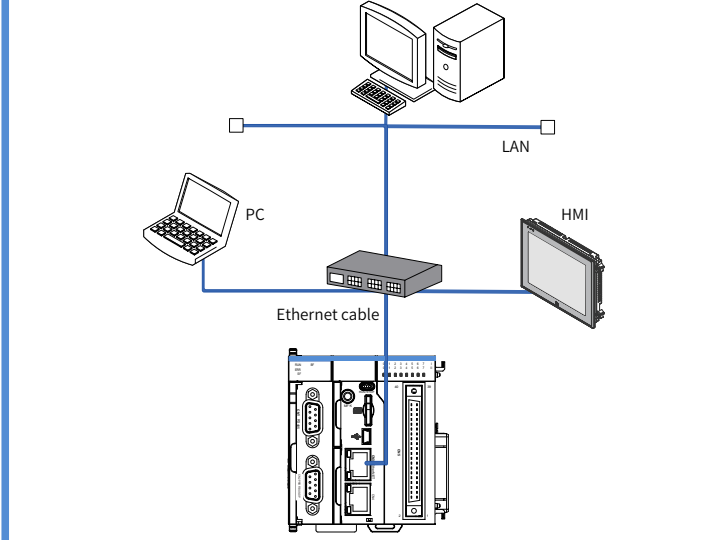

Figure 15 Connection of the CPU module to other equipment via a switch

2) Wiring

To improve equipment communication reliability, the Ethernet cable must be a category 5 shielded twisted pair with iron case molding line.

6. Programming tool downloading

Programming Tool Downloading

The user programming software InPro for Inovance AM600 series medium-sized PLC is free software. You can obtain a software DVD from an Inovance distributor, or download it from the data downloading webpage at Inovance official website www.inovance.cn or from the Inovance page at www.gongkong.com. You can also download reference data about AM600 series PLC products and applications.

Inovance improves its products and data continuously. It is recommended to update software and refer to any updated and issued reference data to facilitate your application design, if necessary.

Programming Environment and Software Installation

Environment Requirements

Hardware requirements: One desktop PC or portable computer running the Windows XP operating system or a later version; 2 GB computer RAM contents, over 5 GB remaining space in the hard disk or SSD. It is recommended that the CPU dominant frequency should be more than 2 GHz; otherwise the running speed is affected.

An LAN network cable can also be used for connection between the PC and the AM610 controller. You are advised to connect AM610 to the LAN via a router. This allows a greater distance between the PC and the AM610, e.g. performing programming on the AM610 located in the workshop by staying at the office. This also achieves a faster interactive communication rate. Therefore, there must be one idle LAN network interface and one network cable in the local network.

A USB cable can also be used for connection between the PC and the AM610 controller. In this case, one USB cable is needed and a MiniUSB plug must be provided at one end of the cable.

7. Operation and Maintenance

Run and Stop Operations

After a program is written to the CPU module, perform the startup and shutdown operations in the following steps.

After a program is written to the CPU module in STOP state, when running the system:

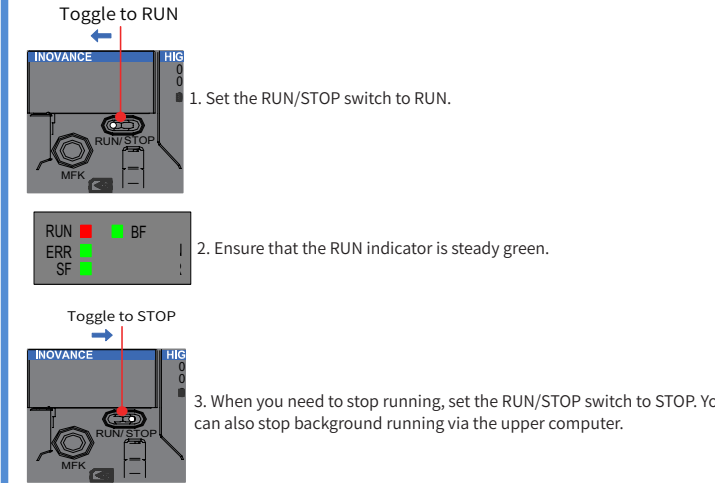

8. Description of Indicators and MFK Key

CPU Module Indicators

Indicator Name	Description
RUN indicator	Indicates the current running state (RUN or stop) of the system ON during running, OFF during shutdown
ERRindicator	Indicates any system fault
SF indicator	System error indicator
BF indicator	Communication error indicator

CPU Module Indicator State Description

LED	Indicator Definition	Solution	
RUN (Green)	Module communication is normal, and the configuration is operating normally.	-	
On	Off	Off	There is no power supply to the module, or the hardware is abnormal. Replace the AM610-CPU1608TP module.
Off	Off	Off	DP communication configuration error. Check whether the bus configuration is correct.
Off	ON	Flashing	Check the hardware configuration and parameter settings. Replace the faulty module according to background diagnosis information.
Off	ON	Off	There is a diagnosis alarm on a slave station.

MFK Key Description

The main function of the MFK key is an IP address reset command key of the PLC main module and is valid when the PLC is in STOP state.

The factory default IP address of the CPU module is 192.168.1.88. If this address is modified, the new IP address may be forgotten so that networking and communication with another PC may fail. At this moment, set the IP address of the CPU module to the factory default address using the MFK key.

1) Press and hold down the MFK key in STOP state until the LED displays the IP address.

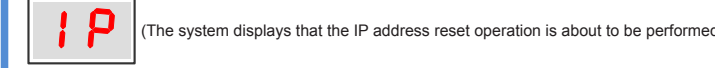

2) If you confirm to reset the IP address, press the MFK key again, and the LED starts to display a countdown starting from 10 to 0.



3) When the countdown reaches 0, press the MFK key to finish the reset operation, and the IP address resetting is completed. After the PLC is powered on again, a new IP address is used.

CPU Module LED Display

When the system fails, the fault code information will be displayed through the LED on the CPU. The display mode is "E.r. and fault code" that appear alternatively. Assume that the fault code is 40, the LED display is shown in the following figure:

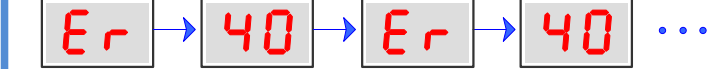

LED Fault Display Information and Countermeasures:

Local Bus of CPU Module and Diagnosis LED Display of I/O Module	Description	Countermeasures
00	No fault	-
40	Local expansion bus error of the CPU	Check whether connection between local rack modules is normal.
41	Configuration error	Check whether the configurations of local rack modules are consistent with those of the background.
42	Module error	Check whether any fault of local rack modules is detected. Detailed fault information can be viewed on the background interface.

High-speed I/O LED Display	Description	Countermeasures
60	High-speed input error	Detailed fault information can be viewed on the background interface.
61	High-speed input alarm	Detailed fault information can be viewed on the background interface.
62	High-speed output error	Detailed fault information can be viewed on the background interface.
63	High-speed output alarm	Detailed fault information can be viewed on the background interface.

ModBus LED Display	Description	Countermeasures
70	ModBus COM0 error	Detailed fault information can be viewed on the background interface.
80	ModBus COM1 error	Detailed fault information can be viewed on the background interface.
90	ModBusTcp error	Detailed fault information can be viewed on the background interface.

PROFIBUS-DP LED Display	Description	Countermeasures
b0	The DP slave station is not ready for data exchange.	Check whether the parameter configurations of the slave station are correct.
b1	DP communication configuration error.	Check whether the DP communication module configurations are correct.
b2	There is a diagnosis alarm on a DP slave station.	Locate the faulty module according to background diagnosis information, and replace the faulty module.
bE	The CPU cannot access the DP master station by using the bus.	The module hardware is faulty. Replace the module.
bF	The master station cannot access the slave station by using the bus.	Check the communication parameter configurations. Check whether the communication cables are properly connected.

9. Module Connection

Connecting the Power, CPU and Expansion Modules

Connection between modules is mainly fixed using a module connection interface, fixed lock catch, etc. Take as a sample the connection of the CPU module to the power module.

1) Slide the lock catch on the CPU module in the direction shown in the figure.

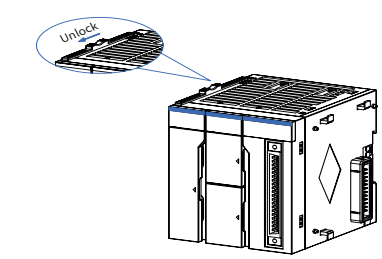

Figure 16 Unlocking by sliding the lock catch in the specified direction

2) Connect the connectors on the CPU and power modules fully and tightly.

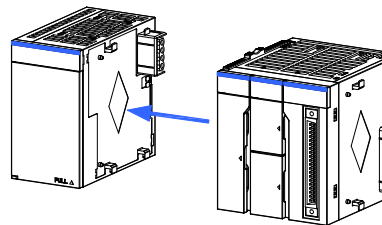

Figure 17 Connecting the connector on the power module

3) Push the lock catch on the CPU module in the direction shown in the figure to finish the connection and locking of both modules.

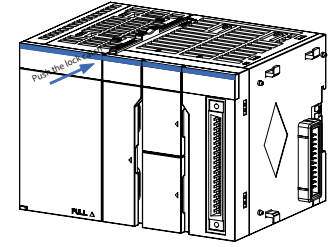

Figure 18 Locking by pushing the lock catch in the specified direction

Connecting the Power, CPU and Expansion Modules

1) Pull out downwards all DIN guide rail mounting hooks on the back of the module (as shown in the following local diagram) until a clicking sound is made.

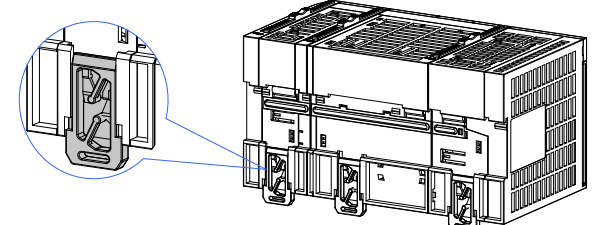

Figure 19 Pulling down hooks on the modules

2) Hang the fixed jaw on the upper side of the module to the upper side of the DIN guide rail in direction A as shown in the figure. Press the module group hard in direction B as shown in the figure until it is fully inserted into the guide rail.

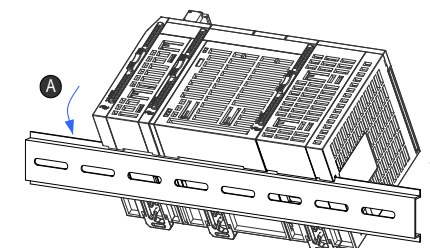

Figure 20 Clipping the module into the DIN rail

3) After locking the DIN guide rail mounting hooks on the module, insert the module to the DIN guide rail. Press upwards until a clicking sound is made. In addition, tools such as screwdrivers shall be used in the case that fingers cannot reach the DIN guide rail mounting hooks.

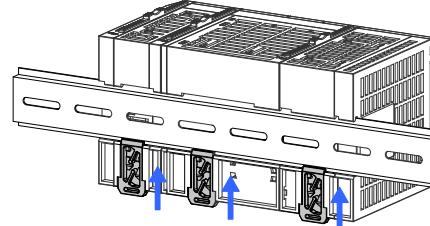

Figure 21 Clipping hooks on the modules in the direction indicated by the arrow

INOVANCE Warranty Agreement

- Inovance provides 18-month free warranty to the equipment itself from the date of manufacturing for the failure or damage under normal use conditions.
- Within the warranty period, maintenance will be charged for the damages caused by the following reasons:
 - Improper use or repair/modification without prior permission
 - Fire, flood, abnormal voltage, other disasters and secondary disasters
 - Hardware damage caused by dropping or transportation after procurement
 - Improper operations
 - Damage out of the equipment (for example, external device factors)
- The maintenance fee is charged according to the latest Maintenance Price List of Inovance.
- If there is any problem during the service, contact Inovance's agent or Inovance directly.
- Inovance reserves the rights for explanation of this agreement.

Suzhou Inovance Technology Co., Ltd.
Address: No.16, Youxiang Road, Yuexi Town, Wuzhong District, Suzhou 215104, P.R. China
Website: <http://www.inovance.com>