

1. Overview

Thank you for buying the GR10-2HCE EtherCAT slave station counting module. This product was independently developed and produced by Inovance Technology.

This module is an extended module based on an EtherCAT bus that supports 2-channel single-ended (or differential) pulse input. It can be used to count pulses in the format of phase A/B 1X frequency, phase A/B 2X frequency, phase A/B 4X frequency, pulse + direction and CW/CCW. It supports up to 200 kHz. Each channel includes 2 high speed inputs (probe), 2 high-speed outputs (comparison outputs), 2 common inputs and 1 common output. It can be used as an encoder axis to read out location and speed data, and also as a general counter to read the number of pulses or other data.

This User Guide mainly describes the specifications, features and uses of the GR10-2HCE EtherCAT slave station counting module. Read these instructions carefully before using this product to ensure the safe and proper use of this product. See the Medium-Sized PLC Programming Manual to understand how to use the user program development environment and the design method of the product's user program. You can download the latest materials from our website <http://www.inovance.com>.

2. Safety Instructions

There are two levels of safety information and precautions: Warning and Caution. Please take appropriate safety measures when using this product.

- WARNING** Indicates the improper operation which, if not avoided, may cause death or serious injury;
- CAUTION** Indicates the improper operation which, if not avoided, may cause moderate or minor injury, as well as equipment damage.

In some cases, failure to follow "Cautions" may also lead to serious consequences. Please make sure to follow both warnings and precautions, otherwise, death, serious injury, or damage to the product or system may result.

Please keep this guide so that it can be read when necessary and forward this guide to the end user.

Control System Design

- WARNING**
 - Provide a safety circuit outside the PLC so that the control system can still work safely once external power failure or PLC fault occurs.
 - Add a fuse or circuit breaker because the module may smoke or catch fire due to extended overcurrent caused by operation above the rated current or load short-circuiting.
- CAUTION**
 - and an upper position limit and lower position limit interlocked circuit must be set in the external circuits of PLC to prevent damage to the machine.
 - To ensure safe operation, for the output signals that may cause critical accidents, please design an external protection circuit and safety mechanism;
 - If the PLC CPU detects an abnormality in the system, all outputs may be closed. However, when a fault occurs in the controller circuit, the user may be unable to control the output. Therefore, it is necessary to design an appropriate external control circuit to ensure normal operation;
 - If the PLC's output units such as relays or transistors are damaged, the output may fail to switch between ON and OFF states according to the commands;
 - The PLC is designed to be used in an indoor electrical environment (overvoltage category II). The power supply must have a system-level surge protector, assuring that overvoltage due to lightning shock can't be applied to the PLC's power supply input terminals, signal input terminals and output terminals, to prevent damage to the equipment.

Disposal

- CAUTION**
 - Treat scrapped modules as industrial waste. Dispose of the battery in accordance with local laws and regulations.

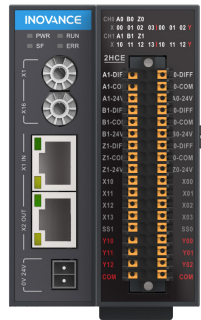

Installation

- WARNING**
 - Installation must be carried out by specialists who have received the necessary electrical training and who have a thorough understanding of electrical knowledge.
 - Disconnect all of the system's external power supplies before assembling, disassembling, or wiring the module. Failure to do so may result in electric shock, module breakdown or malfunction.
 - Do not use the PLC where there are dust, oil smoke, conductive dust, corrosive or combustible gases, or expose it to high temperature, condensation, wind & rain, vibration or impact. Electric shock, fire and malfunctions may also result in damage or deterioration of the product.
 - The PLC is open-type equipment that must be installed in a control cabinet with a lock (cabinet housing protection >IP20). Only the personnel who have received the necessary electrical training and who have a sufficient understanding of electrical knowledge may open the cabinet.

- CAUTION**
 - Prevent metal filings and wire ends from dropping into the PLC's ventilation holes during installation. Failure to comply may result in fire, equipment breakdown, and malfunction.
 - Ensure that there are no foreign objects on the ventilation surface. Failure to comply may result in poor ventilation, which may cause fire, equipment breakdown, and malfunction.
 - Ensure the module is securely connected to the respective connector and firmly hook in the module. Improper installation may result in malfunction, equipment breakdown or collapse.

Wiring

- WARNING**
 - Wiring must be carried out by specialists who have received the necessary electrical training and who have a thorough understanding of electrical knowledge.
 - Disconnect all of the system's external power supplies before wiring. Failure to comply may result in electric shock, module breakdown or malfunction.
 - Install the terminal cover attached to the product before powering-on or operating the device after wiring is completed. Failure to comply may result in electric shock.
 - Properly insulate terminals so that insulation distance between cables will not reduce after cables are connected to terminals. Failure to comply may result in electric shock or damage to the equipment.

- CAUTION**
 - Prevent metal filings and wire ends from dropping into the ventilation holes of the PLC during wiring. Failure to comply may result in fire, equipment breakdown, and malfunction.
 - The external wiring specification and installation method must comply with local regulations. For details, see the wiring section in this guide.
 - To ensure safety of equipment and operator, use cables with a sufficient diameter and correctly connect the cables to the ground.
 - Wire the module correctly after clarifying the connector type. Failure to comply may cause the module and external equipment to break down.
 - Tighten bolts on the terminal block in the specified torque range. If the terminal is not tight, short-circuiting, fire or malfunction may occur. If the terminal is too tight, collapse, short-circuiting, fire or malfunction may occur.
 - If using the connector to connect with external equipment, ensure that you correctly crimp or weld with the tool specified by the manufacturer. If the connection is makes poor contact, short-circuiting, fire or malfunction may occur.
 - A label on the top of the module is to prevent foreign objects from entering the module. Do not remove the label during wiring. Remember to remove the label before system operation, to facilitate ventilation.
 - Do not bundle control wires, communication wires and power cables together. They must be run with distance of more than 100 mm. Otherwise, noise may result in malfunction.
 - Select shielded cables for high-frequency signal input/output in applications with serious interference so as to enhance system anti-interference abilities.

Maintenance and Inspection

- WARNING**
 - Maintenance & inspection must be carried out by personnel who have the necessary electrical training and experience.
 - Do not touch the terminals while the power is on. Failure to comply may result in electric shock or malfunction.
 - Disconnect all of the system's external power supplies before cleaning the module or re-tightening screws on the terminal block or screws of the connector. Failure to comply may result in electric shock.
 - Disconnect all of the system's external power supplies before removing the module or connecting/removing the communication wiring. Failure to comply may result in electric shock or malfunction.
- CAUTION**
 - Thoroughly read these instructions and ensure safety before conducting online modification, forcible output, and RUN/ STOP operations.
 - Disconnect the power supply before installing/removing the extension card.

Disposal

- CAUTION**
 - Treat scrapped modules as industrial waste. Dispose of the battery in accordance with local laws and regulations.

3. Product Information

Model and Nameplate

Mark	Description	Mark	Auxiliary Function
G	General Module	E	EtherCAT comm.
Mark	Description	Mark	Module Type
R	Remote module	HC	High-speed counting
Mark	Series	Mark	Channel
10	10 series	2	2-channel

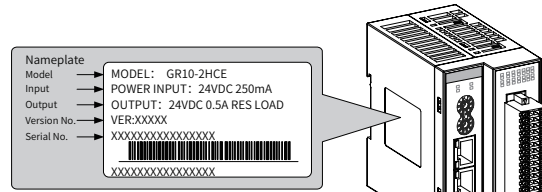

Figure 1 Description of model and nameplate

Model	Classification	Description	Applicable to
GR10-2HCE	EtherCAT slave station counting module	EtherCAT slave station 2-channel counting module	AM600

External Interfaces

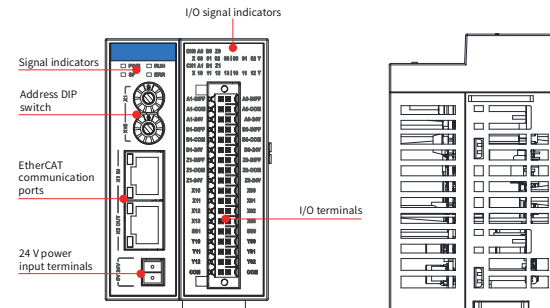

Figure 2 Module interfaces

Interface Name	Function
EtherCAT communication interfaces	X1 IN: EtherCAT input interface X2 OUT: EtherCAT output interface used to connect a back-end EtherCAT slave
Signal indicators	PWR Power indicator Green ON when power supply is switched on RUN Run indicator Green ON when the module is in normal operation SF Module fault indicator Red ON when the module fails ERR State machine error indicator Red ON when state machine error occurs
I/O signal indicators	Corresponding to various I/O signals. ON: I/O active; OFF: I/O inactive
24 V power input terminal	Module power input
Address DIP switch	Slave address setting switch: ADDR1/ADDR0: site address encoder switch; address being set using hexadecimal system; slave decimal address = ADDR1x16+ADDR0x1 (address: 1 to 255)
I/O terminals	For details, refer to "Electrical Design Reference".

General Specifications

Item	Specifications
Power supply voltage	24 VDC (20.4 VDC to 28.8 VDC) (-15% to +20%), an external power supply provided by a user is allowed
Protocol used when communicating with the CPU module	EtherCAT; 100 Mbps
EtherCAT baud rate	Up to 100 m to adapt to the baud rate of EtherCAT master station
Network interface/Network cable	Standard Ethernet and standard Ethernet cable (CAT 5e)
Station number range	1 to 255. An internal address is automatically assigned according to the connection sequence of the network bus.

Specific performance indexes reached are shown in the following table:

Item	Specifications
Communication protocol	EtherCAT protocol
Service supported	CoE (PDO, SDO), FoE
Minimum synchronization period of 6-shaft cam	1250 μs (TYP)
Synchronization mode	The servo uses a DC-distributed clock while I/O uses synchronous input and output.
Physical layer	100BASE-TX

Item	Specifications
Baud rate	100 Mbit/s (100Base-TX)
Duplex mode	Full duplex
Topological structure	Linear topological structure
Transmission medium	For the network cable, refer to the "Wiring" section.
Transmission distance	Less than 100 m between two nodes
EtherCAT frame length	44 bytes to 1498 bytes
Process data	Single frame up to 1486 bytes
Synchronization jitter of two slaves	< 1 μs
Refresh time	1000 digital inputs/outputs: approximately 30 μs; 32 servo axes: approximately 100 μs

Input Specifications

Item	Specifications	
	High speed input (differential or single-ended, A, B and Z inputs, as well as probe input)	Common input
Rated input voltage	24 VDC (+20% to -15%)	24 VDC (+20% to -15%)
Rated input current	7.3 mA (typical) (at 24 VDC)	5.6 mA (typical) (at 24 VDC)
ON current	5 mA or higher	3.5 mA or higher
OFF current	1.5 mA or lower	1.5 mA or lower
Input resistance	3.3 kΩ	4.3 kΩ
Maximum counting rate	800 Kbps (phase A/B, 4X frequency), 200 kHz (single input)	--
Worst duty cycle for 2-phase input	(40%: 60%) to (60%: 40%)	--
Common terminal mode	An independent common terminal for each point	4 points share one common terminal.

Output Specifications

Item	Specifications
Signal name	High-speed output (comparison output) Sink output
Control circuit voltage	5 VDC to 24 VDC
Rated load current	0.5 A/point
Response time when the module is turned ON	1 μs
Response time when the module is turned OFF	0.5 ms
Output frequency	200 kHz (An equivalent external load of 20 mA and above is required at the output of 50 kHz and above)
Common terminal mode	Every 3 points shares one common terminal.

4. Mechanical Design Reference

Mounting Dimensions

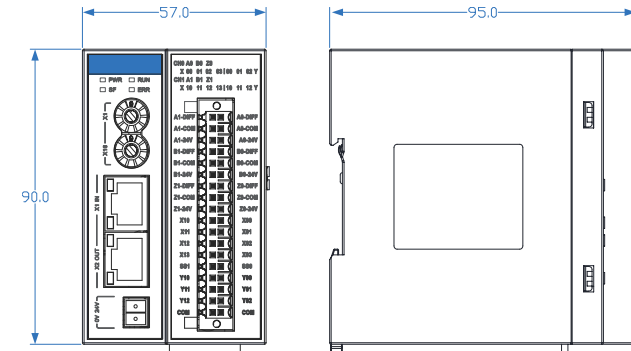
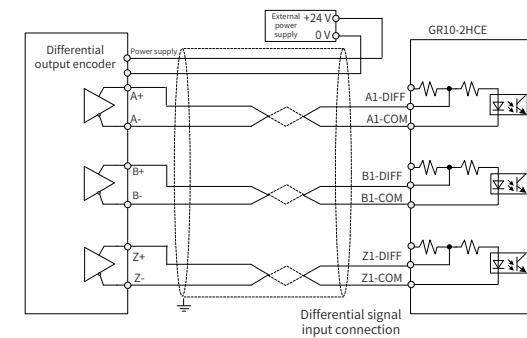
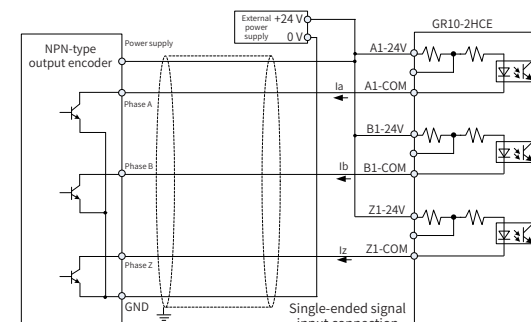

Figure 3 Mounting dimensions (in mm)

5. Electrical Design Reference

User Output Terminal Connection

Signal Connection Diagram



Cable Selection

Cable Name	Model	Applicable Cable Diameter		Manufacturer	Crimping Tool
		Chinese Standard/mm²	American Standard/AWG		
Tubular lug	GTVE07512	0.75	21	Suzhou Yuanli	YAC-5

Those cable lugs are applicable to this module, and the rated cable temperature must be above 75°C.

Cable Preparing Procedures

- Strip back the wire outer coating by 11 to 14 mm. Pass the cable through the tube of proper wire size.
- Insert the exposed end into the hole of the cable lug, and then crimp the cable with a recommended crimping tool.

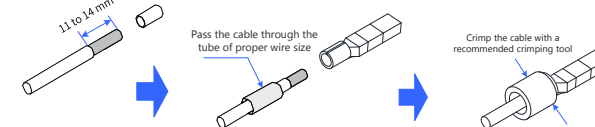

Figure 4 Cable preparing

Terminal Arrangement

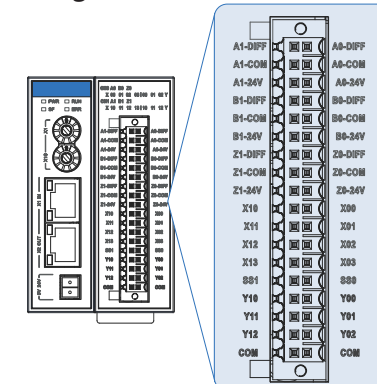
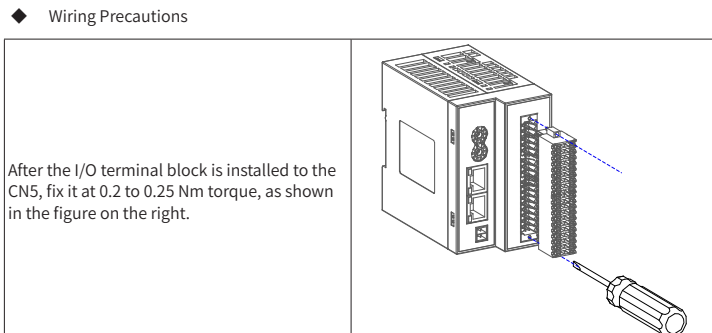
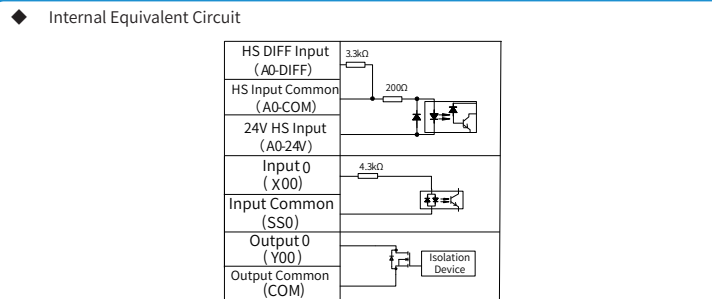

Figure 5 Terminal arrangement

External Wiring and Internal Equivalent Circuit

External Wiring	Signal Name	No.	Signal Name	External Wiring
High-speed differential input (A1-DIFF)	Column B	2	Column A	High-speed differential input (A1-DIFF)
	High-speed input common terminal (A1-COM)	4	High-speed input common terminal (A1-COM)	High-speed input common terminal (A1-COM)
	High-speed 24 V input (A1-24V)	6	High-speed 24 V input (A1-24V)	High-speed 24 V input (A1-24V)
High-speed differential input (B1-DIFF)	Column B	8	Column A	High-speed differential input (B1-DIFF)
	High-speed input common terminal (B1-COM)	10	High-speed input common terminal (B1-COM)	High-speed input common terminal (B1-COM)
	High-speed 24 V input (B1-24V)	12	High-speed 24 V input (B1-24V)	High-speed 24 V input (B1-24V)
High-speed differential input (Z1-DIFF)	Column B	14	Column A	High-speed differential input (Z1-DIFF)
	High-speed input common terminal (Z1-COM)	16	High-speed input common terminal (Z1-COM)	High-speed input common terminal (Z1-COM)
	High-speed 24 V input (Z1-24V)	18	High-speed 24 V input (Z1-24V)	High-speed 24 V input (Z1-24V)
Standard input (X0 probe 1)	Standard input (X0 probe 1)	20	Standard input (X00 probe 1)	Standard input (X00 probe 1)
	Standard input (X01 probe 2)	22	Standard input (X01 probe 2)	Standard input (X01 probe 2)
Standard input (X02 common input)	Standard input (X02 common input)	24	Standard input (X02 common input)	Standard input (X02 common input)
	Standard input (X03 common input)	26	Standard input (X03 common input)	Standard input (X03 common input)
Input common terminal (SS1)	Input common terminal (SS1)	28	Input common terminal (SS1)	Input common terminal (SS1)
	Output (Y00 high-speed comparator output 1)	30	Output (Y00 high-speed comparator output 1)	Output (Y00 high-speed comparator output 1)
Output (Y01 high-speed comparator output 2)	Output (Y01 high-speed comparator output 2)	32	Output (Y01 high-speed comparator output 2)	Output (Y01 high-speed comparator output 2)
	Output (Y12 common output)	34	Output (Y12 common output)	Output (Y12 common output)
Output common terminal (COM)	Output common terminal (COM)	36	Output common terminal (COM)	Output common terminal (COM)



Electrical Shock Protection When Using Inductive Load:
When the inductive load is applied, large back EMF will be produced between contacts and arc discharge is also caused when the inductive load stops. This may result in contact failure or contact sag, shortening the contact lifetime. Therefore, it is recommended to use the products with a built-in relay protection circuit. The freewheel diode must meet the following conditions: ① reverse voltage is 5 to 10 times of load voltage; ② forward current is larger than load current.

- Do not bundle the terminal connection cables together with power cables (high voltage, large current) which produce strong interference signals. Separate it from other cables and avoid cabling in parallel.
- Select recommended cables and pinboards for connection. It is recommended that shielded cables be used as terminal connection cables to enhance capacity of resisting interference.

■ EtherCAT Cable Selection

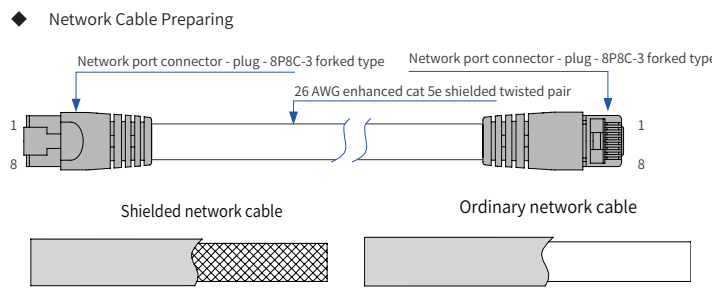

Please use enhanced cat 5e shielded twisted pair with iron case molding line.

◆ Signal Pin Assignment

Pin	Signal	Signal Direction	Signal Description
1	TD+	Output	Data transfer+
2	TD-	Output	Data transfer-
3	RD+	Input	Data receive+
4	--	--	Disabled
5	--	--	Disabled
6	RD-	Input	Data receive-
7	--	--	Disabled
8	--	--	Disabled

◆ Length Requirements
FastEthernet technology demonstrates the cable length between devices can not exceed 100 m when the EtherCAT bus is used. Otherwise, signal attenuation will occur, affecting normal communication.

◆ Technical Requirements
Short circuit, open circuit, displacement and poor contact does not occur during the 100% continuity test.

The EtherCAT bus uses shielded cables to perform network data transfer. Cables with the following specifications are recommended:

Item	Specifications
Cable type	Elastic crossover cable, S-FTP, enhanced cat 5e
Standards compliance	EIA/TIA568A, EN50173, ISO/IEC11801
Conductor type	Twisted pair
Line pair	4

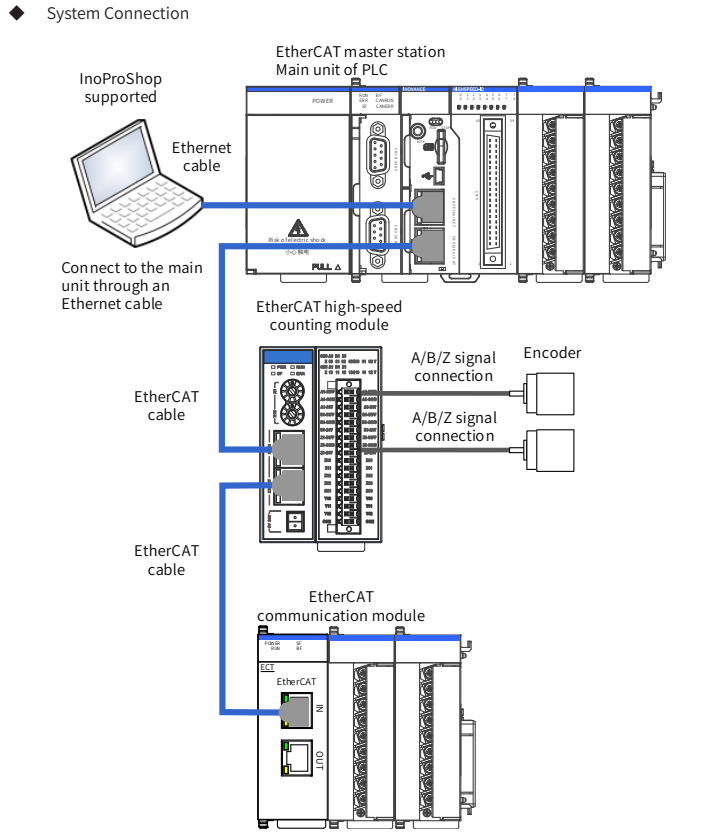
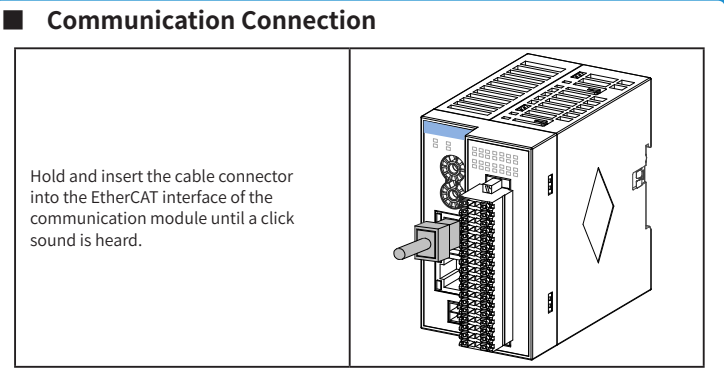

Note: To avoid the influence on the communication cable due to other tension and ensure the stability of communication, secure the cable near the equipment.

■ Fault Indication and Countermeasures for EtherCAT Communication Slave Module

LED Indicators	Description	Solution
RUN	OFF	The EtherCAT master and slave are in initialized state. Check configurations and parameter allocation. Check the communication address. Check whether the network cable specifications and length are consistent with the recommendations.
	Flashing	The EtherCAT slave is in a state other than OP. Check slave configurations. Check whether the module is lost or fails or any unconfigured module exists.
ERR	Flashing	A communication error between the EtherCAT master and slave occurs. Check whether master and slave parameter configurations are correct.
	Flashing	A Counting channel failure occurs. Check the failure code against object dictionary 0x3200, and find a corrective action after the specific failure type is defined according to the failure code.
SF	Solid ON	EtherCAT communication is disconnected. Check whether the network cable is properly connected.

6. Brief Description of Function Block

The AM600 master station operate the module using the functional block, with its name and functions described in the table below:

Name of Functional Block	Description
HC_Counter_ETC	The Enable, counting and frequency measurement of a far-end counter
HC_SetCompare_ETC	Setting and comparing of consistent output of a far-end counter
HC_PresetValue_ETC	Preset value writing of a far-end counter, including software presetting, external DI presetting, and phase Z presetting
HC_TouchProbe_ETC	Latch location reading or latch timing of a far-end counter
HC_Reset_ETC	Resetting of a far-end counter

For instructions regarding each functional block, refer to AM600 commissioning software. The following figure shows the search path:

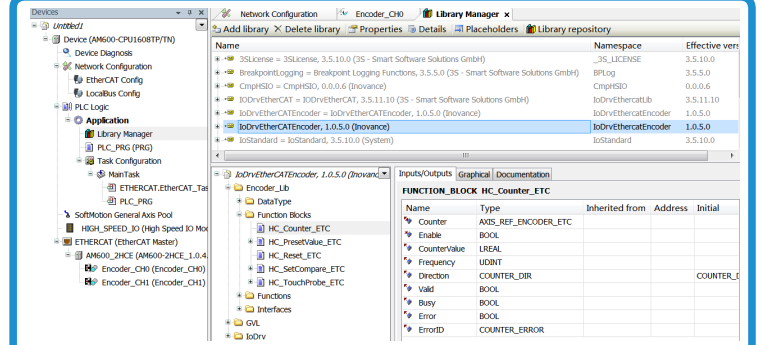

◆ HC_Counter_ETC
The Enable, counting, frequency measurement and counting direction output functional blocks of a far-end counter

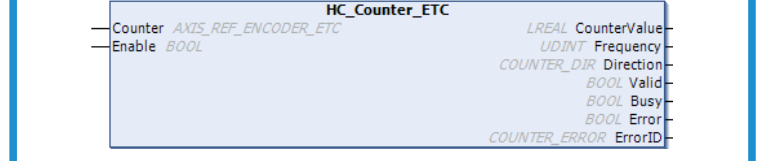

Attribute	Name	Type	Description
In/Out	Counter	ENCODER_REF_ETC	Counter
Inputs	Enable	BOOL	Enable counter
Outputs	CounterValue	LREAL	Counter value
	Frequency	UDINT	Frequency
	Direction	BOOL	Counting direction
	Valid	BOOL	Enabled status of a counter
	Busy	BOOL	Functional block in progress
	Error	BOOL	Indicate an error
	ErrorID	COUNTER_ERROR	Error ID

◆ HC_SetCompare_ETC
Function: to set and compare consistent output of a far-end counter

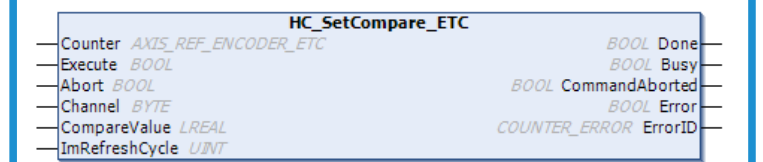

Parameter List

Attribute	Name	Type	Description
In/Out	Counter	ENCODER_REF_ETC	Counter
Inputs	Execute	BOOL	Start the compare function; the rising edge is valid.
	Abort	BOOL	End the compare function; the level is valid
	Channel	BYTE	Channel, range (1, 2)
	CompareValue	LREAL	Comparison value
	ImRefreshCycle	UINT	Output terminal hold time
Outputs	Done	BOOL	Comparison completed
	Busy	BOOL	Functional block in progress
	CommandAborted	BOOL	Functional block ended
	Error	BOOL	Error occurred
	ErrorID	COUNTER_ERROR	Error ID

◆ HC_PresetValue_ETC
Function: to write a preset value into a far-end counter, including software presetting, external DI presetting, and phase Z presetting



7. Programming Examples

The AM600 allows the use of a functional block to operate this module. For instructions regarding a related functional block, refer to the AM600's help file. If any other master station is used, set PDO parameters according to your requirements. The following example shows the AM600 host configured with the GR10-2HCE module to enable the Ch0 of the GR10-2HCE module to count number of phase A/B 1X frequency pulses.

- Enable the function of the AM600 EtherCAT master station.

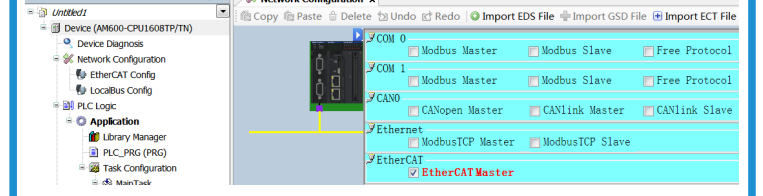

- Double click the GR10-2HCE module on the Network Devices List to add it to the configuration.

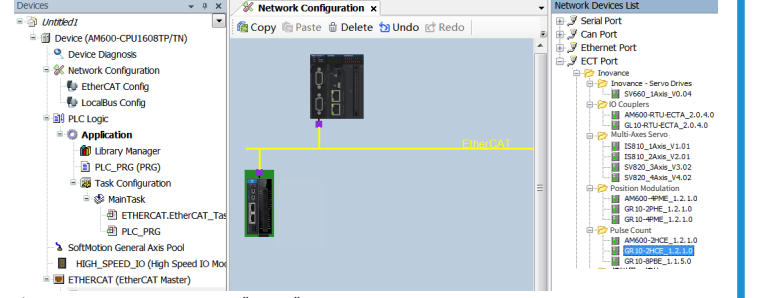

- Set the counting mode as "A/BX1".

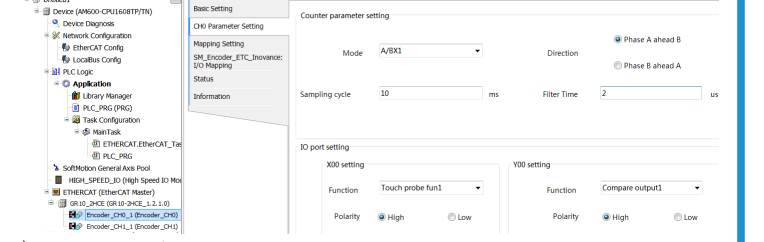

- PLC programming

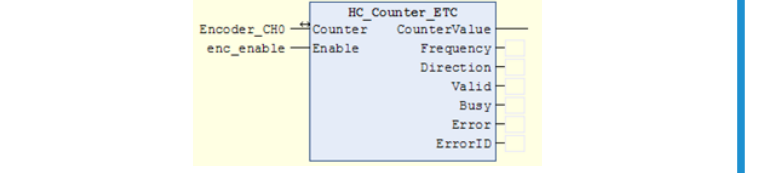

- Log in to and run the module. After variable enc_enable is valid, the counter starts counting.

8. Failure and Solutions

A failure code can be found from object dictionary 3200h:

Code	Reason	Solution
0002h	Preset value error	Check whether a preset value exceeds the limit.
0003h	Comparison value error	Check whether a comparison value exceeds the limit.
0010h	DI terminal presetting settings error	Check whether the DI terminal is set to presetting.
0011h	DI terminal resetting settings error	Check whether the DI terminal is set to resetting.
0012h	DI terminal probe settings error	Check whether the DI terminal is set to probe.
0030h	DO terminal set to comparison	Check whether the DO terminal is set to output comparison.
0050h	High input frequency	Check whether the input frequency exceeds 200 k.
0051h	Linear counter overflowed	The linear counter reaches the maximum value.
0052h	Linear counter underflowed	The linear counter reaches the minimum value.

If the AM600 commissioning software is used, it can detect the following errors:

Code	Reason	Solution
1001h	Preset type out of range	Check whether the preset parameter is within the settable range.
1002h	Counter not enabled	Check whether the enabled counter functional block works normally; after the counter is enabled, execute the related functional block.
1003h	Improper probe parameters	Check whether the probe ID, probe type, probe edge and probe trigger mode fall within the settable range.
1004h	Comparison channel parameter error	Input parameters such as comparison channel ID and comparison value are not within the settable range.
1005h	No error to be cleared	The resetting functional block is invoked when there is no equipment failure.
1006h	Error clearing failure	Error cannot be cleared; please power it off and restart it.
1100h	No related PDO configured for the command	To execute the instruction, a related PDO should be configured. Log off and then add the PDO required for the instruction from the PDO mapping configuration bar.

Parameter List

Attribute	Name	Type	Description
In/Out	Counter	ENCODER_REF_ETC	Counter
Inputs	Execute	BOOL	Start presetting; the rising edge is valid
	Abort	BOOL	End presetting; the level is valid
	TriggerType	BYTE	Internal trigger: 0x01 DI trigger: 0x02 Internal and DI trigger: 0x03 Phase Z trigger: 0x04 Internal and phase Z trigger: 0x05 DI and phase Z trigger: 0x06 Internal, DI and phase Z trigger: 0x07
Outputs	PresetValue	LREAL	Preset value of a counter
	Done	BOOL	Presetting completed
	Busy	BOOL	Functional block in progress
	CommandAborted	BOOL	Functional block ended

Attribute	Name	Type	Description
	Error	BOOL	Error occurred
	ErrorID	COUNTER_ERROR	Error ID

◆ HC_TouchProbe_ETC
Function: to read a latch location or latch time of a far-end counter

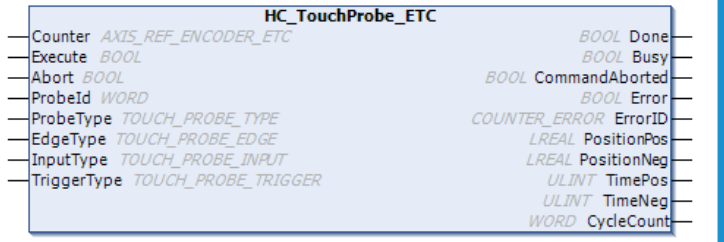

Parameter List

Attribute	Name	Type	Description
In/Out	Counter	ENCODER_REF_ETC	Counter
Inputs	Execute	BOOL	Start presetting; the rising edge is valid
	Abort	BOOL	End a probe; the level is valid
	ProbeId	WORD	Probe ID, range (1, 2)
	ProbeType	TOUCH_PROBE_TYPE	Probe type: time and location
	EdgeType	TOUCH_PROBE_EDGE	Edge type: rising edge, falling edge
	InputType	TOUCH_PROBE_INPUT	External trigger: phase Z, DI terminal
	TriggerType	TOUCH_PROBE_TRIGGER	Trigger type: continuous, single
Outputs	Done	BOOL	Probe capture completed
	Busy	BOOL	Functional block in progress
	CommandAborted	BOOL	Probe capture ended
	Error	BOOL	Error occurred
	ErrorID	COUNTER_ERROR	Error ID
	PositionPos	LREAL	Rising edge latch location
	PositionNeg	LREAL	Falling edge latch location
	TimePos	LINT	Rising edge latch time
	TimeNeg	LINT	Falling edge latch time
	CycleCount	WORD	Edge latch counting

◆ HC_Reset_ETC
Function: to clear counting error of a far-end counter

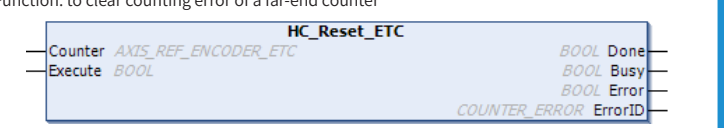

Parameter List

Attribute	Name	Type	Description
In/Out	Counter	ENCODER_REF_ETC	Counter
Inputs	Execute	BOOL	Start resetting; the rising edge is valid
Outputs	Done	BOOL	Resetting done
	Busy	BOOL	Functional block in progress
	Error	BOOL	Error occurred
	ErrorID	COUNTER_ERROR	Error ID

INVANCE Warranty Agreement

- Invance provides an 18-month free warranty to the equipment itself from the date of manufacturing for the failure or damage under normal use conditions.
- Within the warranty period, maintenance will be charged for the damage caused by the following reasons:
 - Improper use or repair/modification without prior permission
 - Fire, flood, abnormal voltage, natural disasters and secondary disasters
 - Hardware damage caused by dropping or transportation after procurement
 - Operations not following the user instructions
 - Damage out of the equipment (for example, external device factors)
- The maintenance fee is charged according to the latest Maintenance Price List of Invance.
- If there is any problem during the service, contact Invance's agent or Invance directly.
- Invance reserves the rights for explanation of this agreement.

Suzhou Invance Technology Co., Ltd.
Address: No.16, Youxiang Road, Yuexi Town, Wuzhong District, Suzhou 215104, P.R. China
Website: <http://www.invance.cn>