



SV670N Series Servo Drive Selection Guide



Industrial
Automation



Intelligent
Elevator



New Energy
Vehicle



Industrial
Robot



Rail
Transit



Data code 19011851 A03

Preface

Introduction

Thank you for purchasing the SV670N series servo drive developed by Inovance.

The SV670N series servo drive is a high-end servo drive designed based on global-leading standards and high-end application needs. It is featured with high speed, high precision, high performance, and tuning-free Function.

The servo drive covers a power range from 0.05 kW to 7.5 kW and carries EtherCAT communication interfaces to work with the host controller for a networked operation of multiple servo drives. The drive comes with the ITune function which supports adaptive stiffness level setting, inertia auto-tuning, and vibration suppression for easy use. The servo drive, together with an MS1 series high-response servo motor (with ultra-low, low or medium inertia) equipped with a 23-bit single-turn/multi-turn absolute encoder, serve to deliver a quiet and stable operation and accurate process control through the fully closed-loop function and internal process segment function.

The drive also offers dynamic braking. The drive aims to achieve quick and accurate position control, speed control, and torque control through high-performance solutions for automation equipment in such industries as electronic manufacturing, lithium batteries, manipulators, packaging, and machine tools.

This manual provides instructions on product selection, including the list of supporting components, technical data on the drive and motor, and the selection guide of cables.

More Documents

Name	Data Code	Description
SV670N Series Servo Drive Selection Guide	19011851	Provides instructions on product selection, including the list of supporting components, technical data on the drive and motor, and the selection guide of cables.
SV670N Series Servo Drive installation Guide	19011862	Presents installation of the servo drive, including installation steps, , mechanical installation, and electrical installation.
SV670N Series Servo Drive Hardware Guide	19011853	Presents electrical design guidance of the equipment, description of terminals, required certificates and standards and solutions to common EMC problems.
SV670N Series Servo Drive Commissioning Guide	19011855	Presents servo commissioning and parameter descriptions, including the operating panel, commissioning software, commissioning procedure and a parameter list.
SV670N Series Servo Drive Function Guide	19011860	Presents functions and parameters, including function overview, basic servo functions, adjustment and parameter list.
SV670N Series Servo Drive Communication Guide	19011865	Presents functions and parameters of the servo drive, including EtherCAT communication configuration, parameter description, and communication application cases.

Name	Data Code	Description
SV670N Series Servo Drive Troubleshooting Guide	19011863	Introduces faults and fault levels, the troubleshooting process, warning codes and fault codes.
SV670N Series Servo Drive Maintenance Guide	19011864	Provides instructions on maintenance and repair of the equipment.
SV670N Series Servo Drive Safety Guide	19011861	Presents the safety function and related certifications and standards, wiring, commissioning process, troubleshooting, and functions.
SV670N Series Servo Drive Manual Package	PS00005527	Provides information on selection, installation, commissioning, function, troubleshooting and parameters of the equipment.

Revision History

Date of Revision	Version	Description
2022-07	A03	<ul style="list-style-type: none"> • Updated the schematic diagram of the drive. • Added information on power loss in electrical specifications. • Deleted manufacturer and model recommendation for the absolute encoder battery. • Updated the selection list.
2022-05	A02	<ul style="list-style-type: none"> • Changed the control circuit and main circuit to 380 VAC to 440 VAC in electrical specifications of the drive (three-phase 380 V). • Modified the description of the model number.
2022-05	A01	<ul style="list-style-type: none"> • Modified information on the parallel communication cable. • Added information on cable models.
2022-04	A00	First release.

Document Acquisition

This manual is not delivered with the product. You can obtain the PDF version by visiting:

- <http://www.inovance.com>.
- Scan the QR code on the equipment to acquire more.

Table of Contents

Preface.....	1
1 Selection	6
2 SV670N Series.....	9
2.1 Product Information	9
2.1.1 Nameplate and model number of the servo drive	9
2.1.2 Components of Servo Drives and Servo Motors.....	10
2.1.2.1 Servo Drives in Size A and Size C (Rated Power: 0.2 kW to 1.5 kW)	10
2.1.2.2 Servo Drives in Size D (Rated Power: 1.5 kW to 3.0 kW)	12
2.1.2.3 Servo Drives in Size E (Rated Power: 5.0 kW to 7.5 kW)	14
2.1.2 Product Dimensions	15
2.2 General Specifications	16
2.2.1 Electrical Specifications	16
2.2.2 Basic Specifications	19
2.2.3 Technical Data of EtherCAT Communication	21
2.2.4 Dynamic Brake Characteristics	21
3 MS1 Motor Series.....	23
3.1 Product Information	23
3.1.1 Nameplate and model number of the servo drive	23
3.1.2 Components of Servo Drives and Servo Motors.....	24
3.1.3 Motor Models	26
3.2 General Specifications	26
3.2.1 Mechanical characteristics.....	26
3.2.2 Overload Characteristics.....	28
3.2.3 Derating Characteristics	29
3.2.4 Temperature curve of the oil sealing.....	29
3.2.5 Load moment of inertia.....	29
3.2.6 Ratio Characteristics for Allowable Load Moment of Inertia of Servo Unit Without Built- in Regenerative Resistor.....	30
3.3 Selection Precautions.....	30
3.4 Motor with Low Inertia and Small Capacity (MS1H1).....	32
3.4.1 MS1H1-05B30CB-A33*Z(-S)	32
3.4.2 MS1H1-10B30CB-A33*Z(-S)	33
3.4.3 MS1H1-20B30CB-A33*Z(-S)	34
3.4.4 MS1H1-40B30CB-A33*Z(-S)	35
3.4.5 MS1H1-55B30CB-A331Z(-S)	36

3.4.6	MS1H1-75B30CB-A33*Z(-S)	37
3.4.7	MS1H1-10C30CB-A331Z(-S)	38
3.5	Motor with Low Inertia and Medium Capacity (MS1H2)	39
3.5.1	MS1H2-10C30CB-A33*Z	39
3.5.2	MS1H2-10C30CD-A33*Z	40
3.5.3	MS1H2-15C30CB-A33*Z	41
3.5.4	MS1H2-15C30CD-A33*Z	42
3.5.5	MS1H2-20C30CD-A331Z	43
3.5.6	MS1H2-20C30CD-A334Z-S4	44
3.5.7	MS1H2-25C30CD-A331Z	45
3.5.8	MS1H2-25C30CD-A334Z-S4	46
3.5.9	MS1H2-30C30CD-A331Z	47
3.5.10	MS1H2-30C30CD-A334Z-S4	48
3.5.11	MS1H2-40C30CD-A331Z	49
3.5.12	MS1H2-40C30CD-A334Z-S4	50
3.5.13	MS1H2-50C30CD-A331Z	51
3.5.14	MS1H2-50C30CD-A334Z-S4	52
3.6	Motor with Medium Inertia and Medium Capacity (MS1H3)	53
3.6.1	MS1H3-85B15CB-A33*Z	53
3.6.2	MS1H3-85B15CD-A33*Z	54
3.6.3	MS1H3-13C15CB-A33*Z	55
3.6.4	MS1H3-13C15CD-A33*Z	56
3.6.5	MS1H3-18C15CD-A33*Z	57
3.6.6	MS1H3-29C15CD-A33*Z	58
3.6.7	MS1H3-44C15CD-A33*Z	59
3.6.8	MS1H3-55C15CD-A33*Z	60
3.6.9	MS1H3-75C15CD-A33*Z	61
3.7	Motor with Medium Inertia and Small Capacity (MS1H4)	62
3.7.1	MS1H4-10B30CB-A33*Z	62
3.7.2	MS1H4-40B30CB-A33*Z(-S)	63
3.7.3	MS1H4-75B30CB-A33*Z(-S)	64
4	Optional parts	66
4.1	List of Optional Parts	66
4.2	Cables	67
4.2.1	Description of the Model Number	67
4.2.2	Cable Type	69
4.2.3	Cable Selection	70

4.3	Peripheral components.....	74
4.3.1	Fuse	74
4.3.2	Electromagnetic contactor	74
4.3.3	Circuit breaker.....	75
4.3.4	AC Input Reactor.....	76
4.3.5	EMC filter	78
4.3.6	Magnetic Ring and Magnetic Buckle	80
4.4	Absolute Encoder Batteries.....	81
5	Compliance List	83

1 Selection

MS1 series servo motors

Servo Drive (SV670*****)				Servo Motor			
Voltage Class	Size	Recommended Drive Model	H01.10 No.	Motor without brake	Motor with brake	Flange Size	Power (kW)
MS1H1 ($n_N=3000\text{rpm}$, $n_{max}=6000\text{rpm}$) series ratings							
Single-phase/ Three-phase 220 V	A	S1R6	00002	MS1H1-05B30CB-A330Z	MS1H1-05B30CB-A332Z	40	0.05
				MS1H1-10B30CB-A330Z	MS1H1-10B30CB-A332Z	40	0.1
				MS1H1-20B30CB-A331Z	MS1H1-20B30CB-A334Z	60	0.2
				MS1H1-20B30CB-A331Z-S	MS1H1-20B30CB-A334Z-S		
Single-phase/ Three-phase 220 V	S2R8	00003	MS1H1-40B30CB-A331Z	MS1H1-40B30CB-A334Z	60	0.4	
			MS1H1-40B30CB-A331Z-S	MS1H1-40B30CB-A334Z-S			
Single-phase/ Three-phase 220 V	C	S5R5	00005	MS1H1-55B30CB-A331Z	-	80	0.55
				MS1H1-55B30CB-A331Z-S			
Single-phase/ Three-phase 220 V	S5R5	00005	00005	MS1H1-75B30CB-A331Z	MS1H1-75B30CB-A334Z	80	0.75
				MS1H1-75B30CB-A331Z-S	MS1H1-75B30CB-A334Z-S		
Single-phase/ Three-phase 220 V	C	S7R6	00006	MS1H1-10C30CB-A331Z	-	80	1.0
				MS1H1-10C30CB-A331Z-S			
MS1H2 ($n_N=3000\text{rpm}$, $n_{max}=6000\text{rpm}/5000\text{rpm}$) series ratings							
Single-phase/ Three-phase 220 V	C	S7R6	00006	MS1H2-10C30CB-A331Z	MS1H2-10C30CB-A334Z	100	1.0
Three-phase 380 V		T5R4	10002	MS1H2-10C30CD-A331Z	MS1H2-10C30CD-A334Z	100	1.0
Single-phase/ Three-phase 220 V	D	S012	00007	MS1H2-15C30CB-A331Z	MS1H2-15C30CD-A334Z	100	1.5
Three-phase 380 V	C	T5R4	10002	MS1H2-15C30CD-A331Z	MS1H2-15C30CB-A334Z	100	1.5
Three-phase 380 V	D	T8R4	10003	MS1H2-20C30CD-A331Z	MS1H2-20C30CD-A334Z-S4	100	2.0
Three-phase 380 V		T8R4	10003	MS1H2-25C30CD-A331Z	MS1H2-25C30CD-A334Z-S4	100	2.5
Three-phase 380 V		T012	10004	MS1H2-30C30CD-A331Z	MS1H2-30C30CD-A334Z-S4	130	3.0
Three-phase 380 V	E	T017	10005	MS1H2-40C30CD-A331Z	MS1H2-40C30CD-A334Z-S4	130	4.0
Three-phase 380 V		T017	10005	MS1H2-50C30CD-A331Z	MS1H2-50C30CD-A334Z-S4	130	5.0
MS1H3 ($n_N=1500\text{rpm}$, $n_{max}=3000\text{rpm}$) series ratings							
Single-phase/ Three-phase 220 V	C	S7R6	00006	MS1H3-85B15CB-A331Z	MS1H3-85B15CB-A334Z	130	0.85
Three-phase 380 V		T3R5	10001	MS1H3-85B15CD-A331Z	MS1H3-85B15CD-A334Z	130	0.85
Single-phase/ Three-phase 220 V	D	S012	00007	MS1H3-13C15CB-A331Z	MS1H3-13C15CB-A334Z	130	1.3
Three-phase 380 V	C	T5R4	10002	MS1H3-13C15CD-A331Z	MS1H3-13C15CD-A334Z	130	1.3

Servo Drive (SV670****I)				Servo Motor			
Voltage Class	Size	Recommended Drive Model	H01.10 No.	Motor without brake	Motor with brake	Flange Size	Power (kW)
Three-phase 380 V	D	T8R4	10003	MS1H3-18C15CD-A331Z	MS1H3-18C15CD-A334Z	130	1.8
Three-phase 380 V		T012	10004	MS1H3-29C15CD-A331Z	MS1H3-29C15CD-A334Z	180	2.9
Three-phase 380 V	E	T017	10005	MS1H3-44C15CD-A331Z	MS1H3-44C15CD-A334Z	180	4.4
Three-phase 380 V		T021	10006	MS1H3-55C15CD-A331Z	MS1H3-55C15CD-A334Z	180	5.5
Three-phase 380 V		T026	10007	MS1H3-75C15CD-A331Z	MS1H3-75C15CD-A334Z	180	7.5
MS1H4 ($n_N=3000\text{rpm}$, $n_{\max}=6000\text{rpm}$) series ratings							
Single-phase/ Three-phase 220 V	A	S1R6	00002	MS1H4-10B30CB-A330Z	MS1H4-10B30CB-A332Z	40	0.1
Single-phase/ Three-phase 220 V		S2R8	00003	MS1H4-40B30CB-A331Z MS1H4-40B30CB-A331Z-S	MS1H4-40B30CB-A334Z MS1H4-40B30CB-A334Z-S	60	0.4
Single-phase/ Three-phase 220 V	C	S5R5	00005	MS1H4-75B30CB-A331Z MS1H4-75B30CB-A331Z-S	MS1H4-75B30CB-A334Z MS1H4-75B30CB-A334Z-S	80	0.75

MCS1 series servo motors with deceleration

Servo Drive (SV670****I)				Servo Motor				
Voltage Class	Size	Recommended Drive Model	H01.10 No.	Model	Motor without brake	Motor with brake	Flange Size	Power (kW)
Single-phase/ Three-phase 220 V	A	S2R8	00003	MCS1H4- 40B30CB-	60F/70Y053-A331R	60F/70Y053-A334R	60	0.4
Single-phase/ Three-phase 220 V					60F/70Y103-A331R	60F/70Y103-A334R		
Single-phase/ Three-phase 220 V					60F/70Y255-A331R	60F/70Y255-A334R		
Single-phase/ Three-phase 220 V	C	S5R5	00005	MCS1H4- 75B30CB-	90F/90Y053-A331R	90F/90Y053-A334R	80	0.75
Single-phase/ Three-phase 220 V					90F/90Y103-A331R	90F/90Y103-A334R		
Single-phase/ Three-phase 220 V					90F/90Y255-A331R	90F/90Y255-A334R		
Single-phase/ Three-phase 220 V	C/D	S7R6/S012	00006/00007	MCS1H1- 10C30CB-	90F/90Y053-A331R	-	80	1.0
Single-phase/ Three-phase 220 V					90F/90Y103-A331R			
Single-phase/ Three-phase 220 V					90F/90Y255-A331R			

Selection

Servo Drive (SV670*****)				Servo Motor				
Voltage Class	Size	Recommended Drive Model	H01.10 No.	Model	Motor without brake	Motor with brake	Flange Size	Power (kW)
Single-phase/ Three-phase 220 V	C	S7R6	00006	MCS1H3- 85B15CB-	115F/120Y053-A331R	115F/120Y053-A334R	130	0.85
Single-phase/ Three-phase 220 V					115F/120Y103-A331R	115F/120Y103-A334R		
Single-phase/ Three-phase 220 V					115F/120Y255-A331R	115F/120Y255-A334R		
Three-phase 380 V		T3R5	10001	MCS1H3- 85B15CD-	115F/120Y053-A331R	115F/120Y053-A334R		
Three-phase 380 V					115F/120Y103-A331R	115F/120Y103-A334R		
Three-phase 380 V					115F/120Y255-A331R	115F/120Y255-A334R		
Single-phase/ Three-phase 220 V	D	S012	00007	MCS1H3- 13C15CB-	115F/120Y053-A331R	115F/120Y053-A334R	1.3	
Single-phase/ Three-phase 220 V					115F/120Y103-A331R	115F/120Y103-A334R		
Single-phase/ Three-phase 220 V					115F/120Y255-A331R	115F/120Y255-A334R		
Three-phase 380 V	C	T5R4	10002	MCS1H3- 13C15CD-	115F/120Y053-A331R	115F/120Y053-A334R	1.8	
Three-phase 380 V					115F/120Y103-A331R	115F/120Y103-A334R		
Three-phase 380 V					115F/120Y255-A331R	115F/120Y255-A334R		
Three-phase 380 V	D	T8R4	10003	MCS1H3- 18C15CD-	115F/120Y053-A331R	115F/120Y053-A334R		
Three-phase 380 V					115F/120Y103-A331R	115F/120Y103-A334R		

2 SV670N Series

2.1 Product Information

2.1.1 Nameplate and model number of the servo drive

Description of the Model Number

SV670		N	S	2R8	I	FS
①		②	③	④	⑤	⑥
① Product Series SV670: SV670 general-purpose servo drive	④ Rated output current			S: 220 V 1R6: 1.6 A 2R8: 2.8 A 5R5: 5.5 A 7R6: 7.6 A 012: 12.0 A 018: 18.0 A 022: 22.0 A 027: 27.0 A		⑤ Model configuration I: General-purpose
② Product type N: Network type P: Pulse type A: CANlink type C: CANopen type						
③ Voltage class S: 220 V T: 380 V	④ Rated output current			T: 380 V 3R5: 3.5 A 5R4: 5.4 A 8R4: 8.4 A 012: 12.0 A 017: 17.0 A 021: 21.0 A 026: 26.0 A		⑥ Non-standard features Blank: standard FH: High protection FS: Functional safety models only come with STO PTC: Motor temperature detection

Description of the nameplate

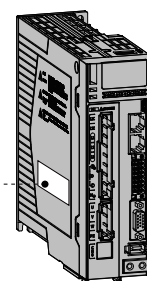
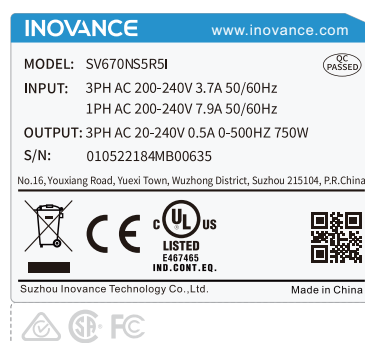

Figure 2-1 Description of the nameplate

Encryption of the production serial number

01050202 4 P 7 00001
① ② ③ ④ ⑤

<p>① Internal code Material code</p>	<p>③ Year 9: 2009 A: 2010 ... P: 2022 ... Note: I/L/O/Q is not used.</p>	<p>⑤ Lot number 00001: 1st in current month 00002: 2nd in current month 00003: 3rd in current month ... Range: 00001 to 99999</p>
<p>② Manufacturer code 4: Suzhou Inovance</p>	<p>④ Month 1: January 2: February ... A: October B: November C: December</p>	

Example: The S/N 010502024P700001 indicates the drive is manufactured in July, 2022.

2.1.2 Components of Servo Drives and Servo Motors

2.1.2.1 Servo Drives in Size A and Size C (Rated Power: 0.2 kW to 1.5 kW)

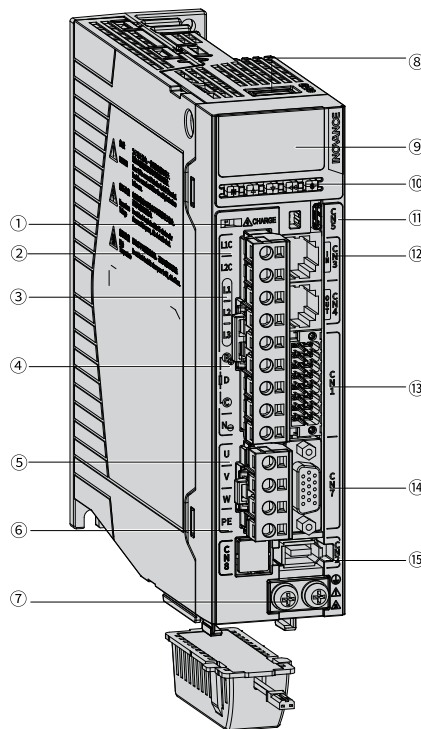

Figure 2-2 Components of servo drive in size A and size C

Table 2-1 Description of components of servo drive in size A and size C

No.	Name	Description
1	CHARGE (bus voltage indicator)	Indicates the electric charge is present in the bus capacitor. When the indicator turns on, charges possibly still exist in the internal capacitor of the servo unit, even if the power supply of the main circuit is OFF. To prevent electric shock, do not touch the power terminals when this indicator lights up.
2	L1C, L2C (control circuit power input terminals)	See the nameplate for the rated voltage class.
3	L1, L2, L3 (main circuit power input terminals) ^[1]	Used as the power input terminals for a three-phase 220 V servo drive. See the nameplate for the rated voltage class.
4	P⊕, D, C (terminals for connecting external regenerative resistor)	Remove the jumper bar between terminals P⊕ and C before connecting an external regenerative resistor between terminals P⊕ and D.
	P⊕, N⊖ (servo bus terminals)	Used by the common DC bus for multiple servo drives.
5	U, V, W (terminals for connecting the servo motor)	Connected to U, V, and W phases of the servo motor.
6	PE grounding terminal	Connected to the grounding terminal of the motor for grounding purpose.
7	Servo drive grounding terminal	Connected to the grounding terminal of the power supply for grounding purpose.
8	CN6 STO safety function terminal ^[2]	Connected to external functional safety signal for functional safety purpose.
9	5-digit LED display	The 5-digit 8-segment LED display is used to show servo system's running state and parameter setting.
10	Keys	M: Used to switch parameters in sequence. ▲: Increases the value of the blinking bit. ▲: Decreases the value of the blinking bit. ◀◀: Used to shift the blinking bit leftwards (Hold down: Turning to the next page when the displayed number exceeds five digits). S: Saves modifications and enters the next menu.
11	CN5 (communication terminals)	Supports online upgrade and background commissioning when the drive is powered on. In USB mode, the terminal only supports download and upload of parameters, and driver firmware update; The terminal uses USB power supply. If there is a fault that cannot be completely reset, disconnect the USB power supply and drive control power, and then power on again.
12	CN3, CN4 (EtherCAT communication terminals)	CN4 (IN): Connected to the master or the last slave device CN3 (OUT): Connected to the next slave device
13	CN1 (control terminal)	Used by reference input signals and other I/O signals.
14	CN7 (second encoder feedback terminal)	Supports pulse encoders.
15	CN2 (encoder connection terminal)	Connected to the motor encoder terminal.

Note

- The built-in regenerative resistor or jumper bar is not available in models S1R6 and S2R8. If an external regenerative resistor is needed for these models, connect it between terminals P⊕ and C.
- [1]: The power input terminals of the 220V servo drive's main circuit are L1, L2, and L3; and the power input terminals of the 380V servo drive's main circuit are R, S, and T.
- [2]: The CN6 STO safety function terminal is only suitable for non-standard models (-FS).

2.1.2.2 Servo Drives in Size D (Rated Power: 1.5 kW to 3.0 kW)

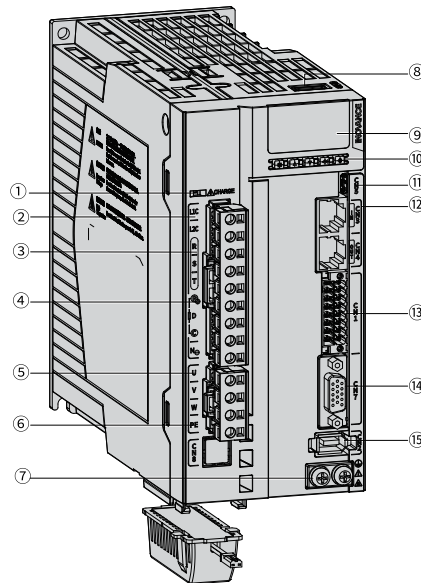

Figure 2-3 Components of servo drive in size D

Table 2–2 Description of components of servo drive in size D

No.	Name	Description
1	CHARGE (bus voltage indicator)	Indicates the electric charge is present in the bus capacitor. When the indicator turns on, charges possibly still exist in the internal capacitor of the servo unit, even if the power supply of the main circuit is OFF. To prevent electric shock, do not touch the power terminals when this indicator lights up.
2	L1C, L2C (control circuit power input terminals)	See the nameplate for the rated voltage class.
3	L1, L2, L3 (main circuit power input terminals) ^[1]	Used as the power input terminals for a three-phase 220 V servo drive. See the nameplate for the rated voltage class.
4	P⊕, D, C (terminals for connecting external regenerative resistor)	Remove the jumper bar between terminals P⊕ and C before connecting an external regenerative resistor between terminals P⊕ and D.
	P⊕, N⊖ (servo bus terminals)	Used by the common DC bus for multiple servo drives.
5	U, V, W (terminals for connecting the servo motor)	Connected to U, V, and W phases of the servo motor.
6	PE grounding terminal	Connected to the grounding terminal of the motor for grounding purpose.
7	Servo drive grounding terminal	Connected to the grounding terminal of the power supply for grounding purpose.

No.	Name	Description
8	CN6 STO safety function terminal ^[2]	Connected to external functional safety signal for functional safety purpose.
9	5-digit LED display	The 5-digit 8-segment LED display is used to show servo system's running state and parameter setting.
10	Keys	M: Used to switch parameters in sequence. ▲: Increases the value of the blinking bit. ▲: Decreases the value of the blinking bit. ◀◀: Used to shift the blinking bit leftwards (Hold down: Turning to the next page when the displayed number exceeds five digits). S: Saves modifications and enters the next menu.
11	CN5 (communication terminals)	Supports online upgrade and background commissioning when the drive is powered on. In USB mode, the terminal only supports download and upload of parameters, and driver firmware update; The terminal uses USB power supply. If there is a fault that cannot be completely reset, disconnect the USB power supply and drive control power, and then power on again.
12	CN3, CN4 (EtherCAT communication terminals)	CN4 (IN): Connected to the master or the last slave device CN3 (OUT): Connected to the next slave device
13	CN1 (control terminal)	Used by reference input signals and other I/O signals.
14	CN7 (second encoder feedback terminal)	Supports pulse encoders.
15	CN2 (encoder connection terminal)	Connected to the motor encoder terminal.

Note

- [1]: The power input terminals of the 220V servo drive's main circuit are L1, L2, and L3; and the power input terminals of the 380V servo drive's main circuit are R, S, and T.
- [2]: The CN6 STO safety function terminal is only suitable for non-standard models (-FS).

2.1.2.3 Servo Drives in Size E (Rated Power: 5.0 kW to 7.5 kW)

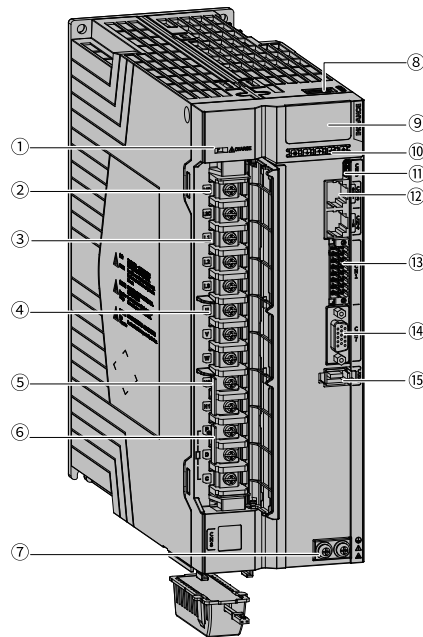

Figure 2-4 Components of servo drive in size E

Table 2-3 Description of components of servo drive in size E

No.	Name	Description
1	CHARGE (bus voltage indicator)	Indicates the electric charge is present in the bus capacitor. When the indicator turns on, charges possibly still exist in the internal capacitor of the servo unit, even if the power supply of the main circuit is OFF. To prevent electric shock, do not touch the power terminals when this indicator lights up.
2	L1C, L2C (control circuit power input terminals)	See the nameplate for the rated voltage class.
3	L1, L2, L3 (main circuit power input terminals) ^[1]	Used as the power input terminals for a three-phase 220 V servo drive. See the nameplate for the rated voltage class.
4	U, V, W (terminals for connecting the servo motor)	Connected to U, V, and W phases of the servo motor.
5	N2, N1 (terminals for connecting external reactor)	Terminals N1 and N2 are jumpered by default. To suppress harmonics in the power supply, remove the jumper between terminals N1 and N2 first and connect an external DC reactor between terminals N1 and N2.
6	P⊕, D, C (terminals for connecting external regenerative resistor)	Remove the jumper bar between terminals P⊕ and C before connecting an external regenerative resistor between terminals P⊕ and D.
7	Servo drive grounding terminal	Connected to the grounding terminal of the power supply for grounding purpose.
8	CN6 STO safety function terminal ^[2]	Connected to external functional safety signal for functional safety purpose.
9	5-digit LED display	The 5-digit 8-segment LED display is used to show servo system's running state and parameter setting.

No.	Name	Description
10	Keys	<p>M: Used to switch parameters in sequence.</p> <p>▲: Increases the value of the blinking bit.</p> <p>▲: Decreases the value of the blinking bit.</p> <p>◀◀: Used to shift the blinking bit leftwards (Hold down: Turning to the next page when the displayed number exceeds five digits).</p> <p>S: Saves modifications and enters the next menu.</p>
11	CN5 (communication terminals)	<p>Supports online upgrade and background commissioning when the drive is powered on.</p> <p>In USB mode, the terminal only supports download and upload of parameters, and driver firmware update;</p> <p>The terminal uses USB power supply. If there is a fault that cannot be completely reset, disconnect the USB power supply and drive control power, and then power on again.</p>
12	CN3, CN4 (EtherCAT communication terminals)	CN4 (IN): Connected to the master or the last slave device CN3 (OUT): Connected to the next slave device
13	CN1 (control terminal)	Used by reference input signals and other I/O signals.
14	CN7 (second encoder feedback terminal)	Supports pulse encoders.
15	CN2 (encoder connection terminal)	Connected to the motor encoder terminal.

Note

- [1]: The power input terminals of the 220V servo drive's main circuit are L1, L2, and L3; and the power input terminals of the 380V servo drive's main circuit are R, S, and T.
- [2]: The CN6 STO safety function terminal is only suitable for non-standard models (-FS).

2.1.2 Product Dimensions

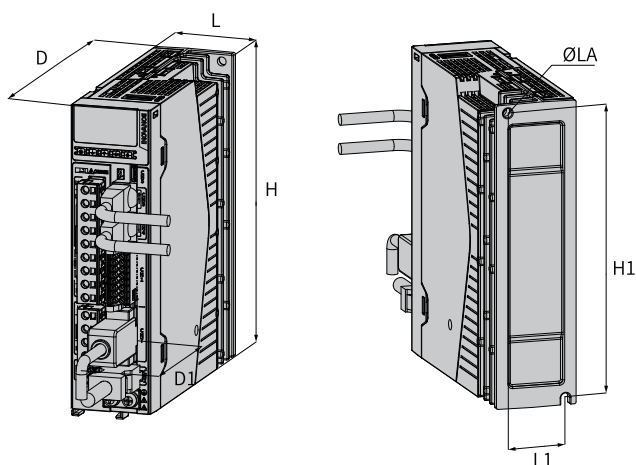

Size	L	H	D	L1	H1	D1	ØLA	Tightening Torque	Weight
	Unit: mm (in.)							Unit: N·m	Unit: kg
A	45.5 (1.57)	170 (6.69)	150 (5.91)	33 (1.10)	161 (6.34)	75 (2.95)	2-M4	1.2	0.96
C	55±1 (2.17±0.04)	170 (6.69)	173±1 (6.81±0.04)	44 (1.73)	160 (6.30)	75 (2.95)	2-M4	1.2	1.3
D	80±1 (3.15±0.04)	170 (6.69)	183 (7.20)	71 (2.80)	160 (6.30)	75 (2.95)	3-M4	1.2	1.8
E	90 (3.54)	250 (9.84)	230 (9.06)	78 (3.07)	240.5 (9.47)	75 (2.95)	4-M4	1.2	3.6

2.2 General Specifications

2.2.1 Electrical Specifications

Single-phase 220 V drive

Item		Size A		Size C		Size D
Servo drive model SV670****I		S1R6	S2R8	S5R5	S7R6	S012
Drive Power (kW)		0.2	0.4	0.75	1.0	1.5
Max. applicable motor capacity (kW)		0.2	0.4	0.75	1.0	1.8
Power supply equipment capacity (kVA)		1.4	2.8	4.6	6.0	8.0
Continuous output current (Arms)		1.6	2.8	5.5	7.6	12.0
Max. output current (Arms)		5.8	10.1	16.9	23.0	32.0
Main circuit	Continuous input current (Arms)	2.3	4.0	7.9	9.6	12.8
	Main circuit power supply	Single-phase 200 VAC–240 VAC, -10 to +10%, 50 Hz/60Hz				
	Energy Loss (W) ^[1]	12	23.8	38.2	47.32	69.84
Control circuit	Control circuit power supply	Single-phase 200 VAC–240 VAC, -10 to +10%, 50 Hz/60Hz				
	Energy Loss (W) ^[1]	16				

Item		Size A		Size C		Size D
Braking resistor	Resistance (Ω)	Optional	Optional	50	25	25
	Resistor power (W)	Optional	Optional	50	80	80
	Min resistance of external resistor (Ω)	40	40	40	20	15
	Max. Braking Energy Absorbed by the Capacitor (J)	9.3	18.59	32.42	32.42	47.68
	Braking resistor	All models in the series support built-in and external braking resistors. But Size A does not come with a built-in braking resistor as standard				
Cooling method		Self-cooling		Air cooling		
Overvoltage class		III				

Three-phase 220 V drive

Item		Size A		Size C		Size D	Size E		
Servo drive model SV670****I		S1R6	S2R8	S5R5	S7R6	S012	S018	S022	S027
Drive Power (kW)		0.2	0.4	0.75	1.0	1.5	2.0	2.5	5.0
Max. applicable motor capacity (kW)		0.2	0.4	0.75	1.0	1.8	2.0	2.5	5.0
Power supply equipment capacity (kVA)		1.21	2.42	3.84	5.05	6.68	8.33	10.42	20.08
Continuous output current (Arms)		1.6	2.8	5.5	7.6	12.0	18.0	22.0	27.0
Max. output current (Arms)		5.8	10.1	16.9	23.0	32.0	45	55	67.5
Main circuit	Continuous input current (Arms)	1.1	2.3	4.4	5.1	8.0	8.7	11.0	23.8
	Main circuit power supply	3-phase 200 VAC–240 VAC, -10 to +10%, 50 Hz/60 Hz							
	Energy Loss (W) ^[1]	12	23.8	38.2	47.32	69.84	120	125	200
Control circuit	Control circuit power supply	Single-phase 200 VAC–240 VAC, -10 to +10%, 50 Hz/60Hz							
	Energy Loss (W) ^[1]	16							
Braking resistor	Resistance (Ω)	Optional	Optional	50	25	25	20	20	20
	Resistor power (W)	Optional	Optional	50	80	80	100	100	100
	Min resistance of external resistor (Ω)	40	40	40	20	15	20	20	20
	Max. Braking Energy Absorbed by the Capacitor (J)	9.3	18.59	32.42	32.42	47.68	78.19	114.43	114.43
	Braking resistor	All models in the series support built-in and external braking resistors. But Size A does not come with a built-in braking resistor as standard					Built-in and external resistor is supported		
Cooling method		Self-cooling		Air cooling					
Overvoltage class		III							

Three-phase 380 V drive

Item		Size C		Size D		Size E		
Servo drive model SV670****I		T3R5	T5R4	T8R4	T012	T017	T021	T026
Drive Power (kW)		1.0	1.5	2.0	3.0	5.0	6.0	7.5
Max. applicable motor capacity (kW)		1.0	1.5	2.0	3.0	4.4	5.5	7.5
Power supply equipment capacity (kVA)		6.05	9.08	10.23	15.15	22.25	25.0	31.25
Continuous output current (Arms)		3.5	5.4	8.4	12.0	17.0	21.0	26.0
Max. output current (Arms)		11.0	14.0	20.0	30.0	42.5	52.5	65.0
Main circuit	Continuous input current (Arms)	2.4	3.6	5.6	8.0	12.0	16.0	21.0
	Main circuit power supply	3-phase 380 VAC-440 VAC, -10 to +10%, 50 Hz/60 Hz						
	Energy Loss (W) ^[1]	39.5	63.25	94.82	135.47	187.62	228.28	258.63
Control circuit	Control circuit power supply	Single-phase 380 VAC-440 VAC, -10 to +10%, 50 Hz/60 Hz						
	Energy Loss (W) ^[1]	16						
Braking resistor	Resistance (Ω)	100	100	50	50	35	35	35
	Resistor power (W)	80	80	80	80	100	100	100
	Min resistance of external resistor (Ω)	80	60	45	40	35	25	25
	Max. Braking Energy Absorbed by the Capacitor (J)	28.23	34.28	50.41	50.41	82.67	120.98	120.98
	Braking resistor	Built-in braking resistor						
Cooling method		Air cooling						
Overvoltage class		III						

Note

- [1] Main circuit energy loss refers to the energy loss under rated output current of the servo drive.
- Select the external regenerative resistor according to actual operating conditions.

2.2.2 Basic Specifications

Item		Description	
Basic Specifications	Control mode	IGBT PWM control, sine wave current drive mode 220 V, 380 V: Single-phase/Three-phase full bridge rectification	
	Encoder feedback	23-bit multi-turn absolute encoder, which can be used as an incremental encoder in absence of the battery	
	Conditions for use	Operating/Storage temperature ^[1]	-5°C to 55°C (average load ratio not exceeding 80% in ambient temperatures between 45°C to 55°C) (non freezing)/ -40°C to 70°C
		Operating/Storage humidity	Below 90% RH (no condensation)
		Vibration resistance	Operation: <ul style="list-style-type: none"> • 5 Hz-8.4 Hz: 3.5 mm displacement • 8.4 Hz-200 Hz: 1g Product package: <ul style="list-style-type: none"> • 5 Hz-100 Hz: 0.01g²/Hz • 200 Hz: 0.001g²/Hz • Grms=1.14g
		Impact resistance	19.6m/s ²
		IP rating	IP20 Note: excluding terminals (IP00)
		Pollution degree	PD2
		Altitude	The maximum altitude is 2000 m. <ul style="list-style-type: none"> • For altitudes not higher than 1000 m, derating is not required • Derating is required for altitudes above 1000 m (derate 1% for every additional 100 m) • For altitudes above 2000 m, contact Inovance
		Speed/ Torque control mode	Performance
Speed loop bandwidth	3.5 kHz		
Torque control accuracy (repeatability)	±2%		
Soft startup time	0s to 65s (Acceleration and deceleration can be set separately.)		
Input signal	Speed reference		Source of network-type references: EtherCAT communication
	Torque reference		Local mode and local multi-speed supported
Position control mode	Performance	Positioning time	1 ms to 10 ms
	Input signal	Position reference	Source of network-type references: EtherCAT communication Local mode supported

Item		Description		
Position control mode	Digital input (DI) signal	5 DIs DI1–DI2: normal DI (rising edge (24 V input high to low) input delay: 100 us, falling edge (24 V input low to high) input delay: 50 us, voltage range: 12 V–24 V) DI4–DI5: fast DI (rising edge (24 V input high to low) input delay: 30 us, falling edge (24 V input low to high) input delay: 5 us, voltage range: 12 V–24 V) P-OT (positive limit switch) N-OT (negative limit switch) HomeSwitch (home switch) TouchProbe1 (touch probe 1) TouchProbe2 (touch probe 2)		
	Digital output signal	2 DOs With-load capacity: 50 mA Voltage range: 5 V to 30 V S-RDY: Servo ready TGON: motor rotation output Comparison output, brake output, EDM output		
Built-in functions	Overtravel (OT) limit		The servo drive stops immediately when P-OT or N-OT is active	
	Protective functions		Providing protections against overcurrent, overvoltage, undervoltage, overload, main circuit detection error, heatsink overheat, overspeed, encoder error, CPU error, and parameter error	
	LED display		Main circuit CHARGE indicator, 5-digit LED display	
	Vibration Suppression		Four notches (including two adaptive notches) available, 50 Hz to 5000 Hz	
	Communication function	Software commissioning		-
		Communication protocol		EtherCAT
		Multi-station communication		Maximum number of slaves: 255
		Axis address setting		No physical knob, set to 0 to 255 through the software
Function		Including status display, user parameter setting, monitored value display, fault tracing display, JOG and auto-tuning, and speed/torque reference signal observation		
Others		Gain tuning, alarm record, JOG		

Note

[1] The temperature of the environment where the servo drive is installed must be within the range specified in the preceding table. When the servo drive is installed into a control cabinet, the temperature inside the cabinet must also be within this range.

2.2.3 Technical Data of EtherCAT Communication

Item		Specification
Ether-CAT Basic per- for- mance of slave	Communication protocol	EtherCAT protocol
	Available services	CoE (PDO, SDO)
	Synchronization mode	Distributed clock
	Physical layer	100BASE-TX
	Baud rate	100 Mbit/s (100Base-TX)
	Duplex mode	Full duplex
	Topology	Linear
	Transmission medium	Shielded cables of Cat 5e or higher
	Transmission distance	Less than 100 m between two nodes (with proper environment and cables)
	Number of slaves	Up to 65535 by protocol, not exceeding 100 in actual use
	EtherCAT frame length	44 bytes to 1498 bytes
	Process Data	A maximum of 1486 bytes per Ethernet frame
	Synchronous jitter of two slaves	< 1 us
	Update time	About 30us for 1000 DI/DOs About 100 μs for 100 servo axes Define different update time for different interfaces.
Communication code error rate	10 ⁻¹⁰ Ethernet standard	
Ether-CAT Configu- ration unit	Number of FMMU units	8
	Number of storage synchronization management units	8
	Process data RAM	8 kB
	Distributed Clock	64 bits
	e2prom capacity	32 kbit

2.2.4 Dynamic Brake Characteristics

According to the motor model, initial speed and load inertia, the dynamic braking distance can be estimated. The approximate value of the dynamic braking distance can be calculated by the following formula. For the accurate value, please use the dynamic braking calculation function provided by our software.

Maximum braking distance s (turn) is:

$$s = \frac{V_0}{60} (t_e + (\tau_1 + \tau_2 V_0^2) (1 + \frac{J_L}{J_M}))$$

The coefficient is as follows:

$$\tau_1 = \frac{2R_s J}{3p_n^2 \Psi_f^2} = \frac{10000\pi^2 R_s J}{9K_e^2}$$

$$\tau_2 = \frac{\pi^2 L_d^2 J}{4050R_s \Psi_f^2} = \frac{100L_d^2 \pi^4 P_n^2 J}{243R_s K_e^2}$$

$$\Psi_f = \frac{\sqrt{6}K_e}{100\pi P_n}$$

- V_0 : Maximum feedback speed
- t_e : Dynamic brake program and relay delay
- J_L : Load moment of inertia
- J_M : Motor moment of inertia
- P_n : Number of motor pole pairs
- R_s : Stator resistance (Ω)
- L_q, L_d : q-axis inductance (mH), d-axis inductance (mH).

3 MS1 Motor Series

3.1 Product Information

3.1.1 Nameplate and model number of the servo drive

MS1 H4 - 75B 30C B A3 3 1 Z - S
 ① ② ③ ④ ⑤ ⑥ ⑦ ⑧ ⑨ ⑩

<p>① MS1 series servo motor</p>	<p>④ Rated speed (rpm)</p> <p>One letter and two digits</p> <p>B: x 10</p> <p>C: x 100</p> <p>Example: 30C: 3,000 rpm</p>	<p>⑧ Brake, Reducer and Oil Sealing [1]</p> <p>0: No oil seal and brake</p> <p>1: With oil seal</p> <p>2: With brake</p> <p>4: With oil seal and brake</p>
<p>② Inertia and Capacity</p> <p>H1: low inertia, small capacity</p> <p>H2: low inertia, medium capacity</p> <p>H3: medium inertia, medium capacity</p> <p>H4: medium inertia, small capacity</p>	<p>⑤ Voltage Class (V)</p> <p>B: 220</p> <p>D: 380</p>	<p>⑨ Series</p> <p>Z: Z series</p>
<p>③ Rated Power (W)</p> <p>One letter and two digits</p> <p>B: x 10</p> <p>C: x 100</p> <p>Example: 75B: 750 W</p>	<p>⑥ Encoder type</p> <p>One letter and one digit</p> <p>A3: 23-bit multi-turn absolute encoder</p> <p>⑦ Shaft Connection Mode</p> <p>3: Solid, with key and threaded hole</p>	<p>⑩ Cable Connection and Cooling</p> <p>Blank: terminal type, natural cooling</p> <p>-S^[2]: flying leads type, natural cooling</p> <p>-S4: flying leads type motor S4</p>

Note

- [1]: Oil seals are provided as standard for all motors except the 40-flange model.
- [2]:-S flying leads type only applies to 40/60/80-flange motors.

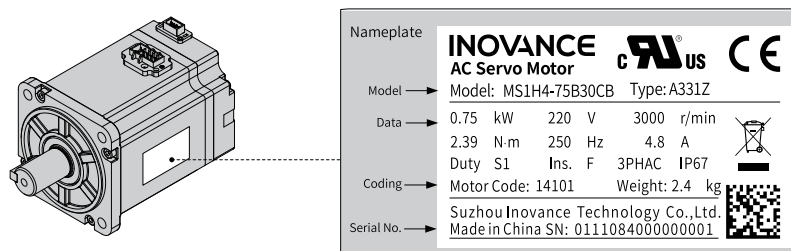

Figure 3-1 Nameplate and model number of the servo drive

Note

The SV660P series servo drive can work with a servo motor configured with a 23-bit single-turn or multi-turn absolute encoder.

3.1.2 Components of Servo Drives and Servo Motors

Servo Motors in Flange Sizes 40/60/80

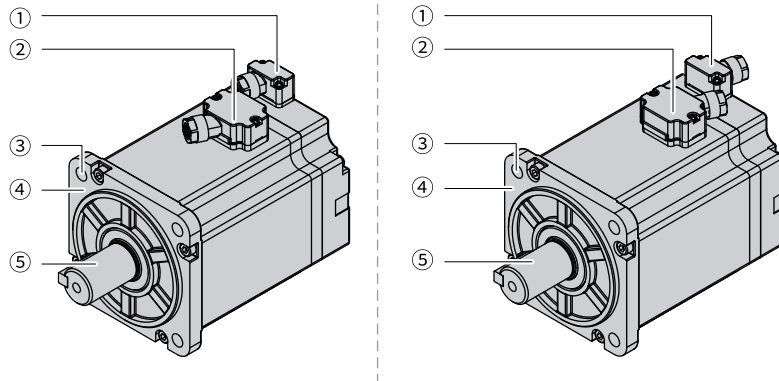

Figure 3-2 Components of terminal-type motors (Left: motor with front cable outlet; Right: motor with rear cable outlet)

Table 3-1 Components of terminal-type motors

No.	Name
①	Encoder connector
②	Power connector
③	Mounting screw through-hole
④	Mounting flange face
⑤	Shaft extension (keyed)

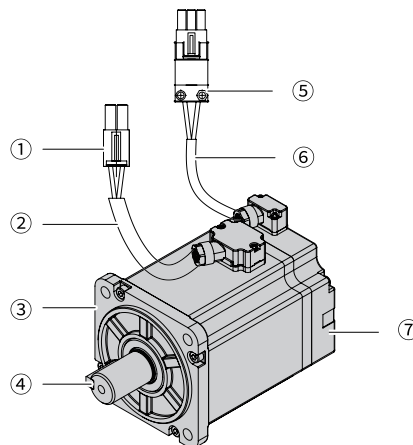

Figure 3-3 Components of flying leads type motors

Table 3-2 Components of flying leads type motors

No.	Name
①	Power cable connector
②	Power cable
③	Mounting flange face
④	Output shaft
⑤	Encoder connector
⑥	Encoder cable
⑦	Encoder (detection part)

Servo Motors in Flange Sizes 100/130/180

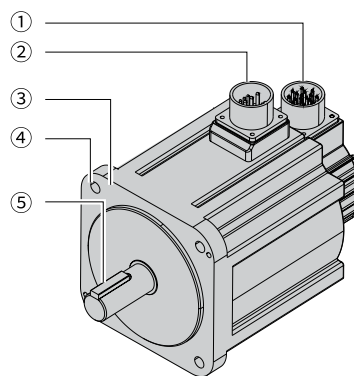

Figure 3-4 Components of servo drives in flange sizes 100/130/180

Table 3-3 Components of servo drives in flange sizes 100/130/180

No.	Name
①	Encoder connector
②	Power cable connector
③	Mounting flange face
④	Mounting screw through-hole
⑤	Shaft extension (keyed)

3.1.3 Motor Models

Motor		Rated Output Capacity (kW)	Rated speed (Max. Rated Speed) (RPM)	Encoder	IP rating
Low inertia, small capacity	<p>MS1H1</p> 	0.05, 0.1, 0.2, 0.4, 0.55, 0.75, 1.0	3000 (6000)	A3: 23-bit multi-turn absolute encoder	IP67
Low inertia, medium capacity	<p>MS1H2</p> 	1.0, 1.5, 2.0, 2.5, 3.0, 4.0, 5.0	3000 (6000/5000)	A3: 23-bit multi-turn absolute encoder	IP67
Medium inertia, medium capacity	<p>MS1H3</p> 	0.85, 1.3, 1.8, 2.9, 4.4, 5.5, 7.5	1500 (3000)	A3: 23-bit multi-turn absolute encoder	IP67
Medium inertia, small capacity	<p>MS1H4</p> 	0.1, 0.4, 0.75	3000 (6000)	A3: 23-bit multi-turn absolute encoder	IP67

3.2 General Specifications

3.2.1 Mechanical characteristics

Item	Description
Duty type	S1(Continuous working)
Vibration level ^[1]	V15
Insulation resistance	500VDC, above 10 MΩ
Excitation mode	Permanent magnetic
Installation Mode	Flange
Heat resistance level	F
Insulation voltage	1500 VAC, 1 minute (class 220 V) 1800 VAC, 1 minute (class 380 V)
IP rating of the enclosure	IP67 (excluding shaft opening and flying leads type motor connectors)

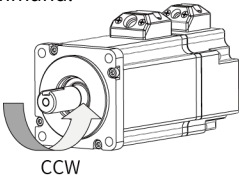
Item		Description
Direction of rotation		Rotates counterclockwise when viewed from the shaft extension side with the forward run command.  CCW
Environment conditions	Ambient temperature	0°C to 40°C (non-freezing) (Derate based on the derating curve for temperatures above 40°C.)
	Ambient humidity	20%–80% (no condensation)
	Installation location	<ul style="list-style-type: none"> Free from corrosive or explosive gases Well ventilated and with minimum amount of dust, waste and moisture. Convenient for inspection and cleanup. Below 1000 m (derating required for altitudes above 1000 m) • See the “3.2.3 Derating Characteristics” on page 29 motor derating curve for details. Away sources that may generate strong magnetic field Away from heating sources such as a heating stove Use the motor with oil seal in places with grinding fluid, oil mist, iron powders or cuttings.
	Storage	Observe the following requirements for storage of a de-energized motor: <ul style="list-style-type: none"> Temperature: -20°C to +60°C (non-freezing) Humidity: 20% to 80% RH (no condensation)
Impact resistance ^[2]	Impact acceleration (flange face as standard)	490m/s ²
	Times of impact	2
Vibration resistance ^[3]	Vibration acceleration (flange face as standard)	49m/s ²

Note

- [1] Vibration grade V15 indicates that the amplitude of vibration is less than 15 μm when a single servo motor rotates at its rated value.
- [2] For a motor shaft mounted horizontally, the impact resistance level in the up and down directions is shown in the preceding table.
- [3] For a servo motor shaft mounted horizontally, the vibration resistance level in the up/down, left/right, and front/rear directions is shown in the preceding table.
- The vibration intensity applied to the motor varies with applications.

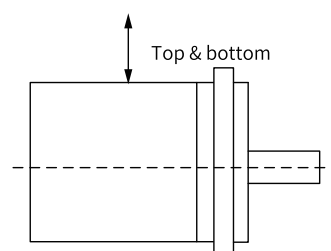

Figure 3-5 Impact applied on the motor

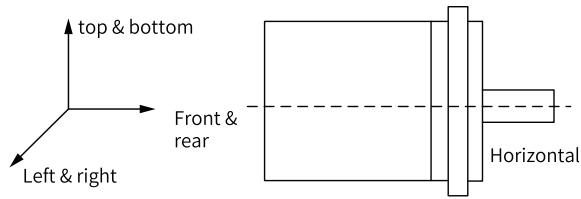

Figure 3-6 Vibration present on the motor

3.2.2 Overload Characteristics

The equipment is compliant with NEC and CEC requirements and equipped with protective functions against overload and overtemperature.

To protect motors with different loads, set motor overload protection gain based on the overload capacity of the motor. Use the default gains in general conditions, however, when one of the following condition occurs, change the gains based on the temperature rise condition of the motor:

- The motor operates in environments with high temperature.
- The motor is in cyclic motion featuring a short motion cycle and frequent acceleration/ deceleration.

Motor overload protection is shown by the following inverse time curve.

Load Ratio (%)	Operating time (s)
120	230
130	80
140	40
150	30
160	20
170	17
180	15
190	12
200	10
210	8.5
220	7
230	6
240	5.5
250	5
300	3
350	2

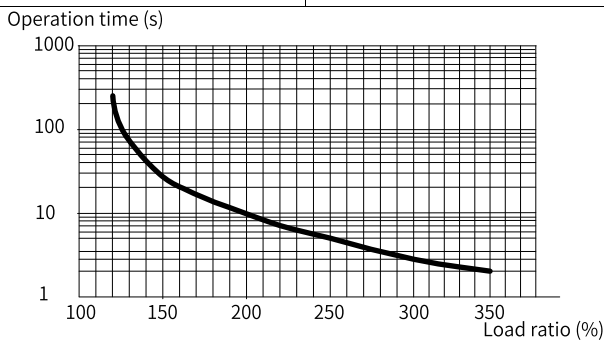

Figure 3-7 Motor overload curve

Note

- The maximum torque of MS1H4 models is 3.5 times the rated torque.
- Except for the 2.9 kW model, the maximum torque of MS1H3 is 2.5 times the rated torque.
- For 2.9 kW, the maximum torque is 2 times the rated torque.

3.2.3 Derating Characteristics

• Altitude-based derating curve

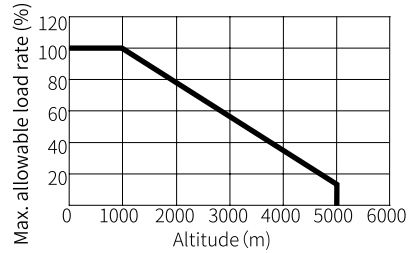

• Temperature-based derating curve

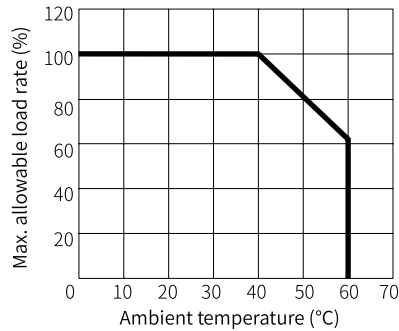

3.2.4 Temperature curve of the oil sealing

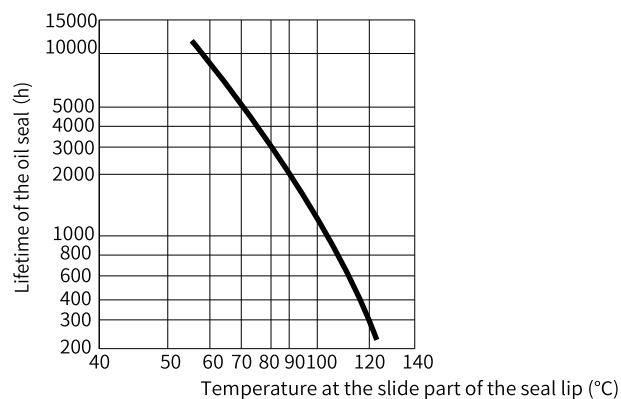

3.2.5 Load moment of inertia

The load moment of inertia represents the inertia of the load. The larger the load moment of inertia is, the weaker the responsiveness is. An excessively high inertia may result in unstable motion. The

allowable load moment of inertia () of the motor is restricted. This value is provided strictly as a guideline and results depend on the motor driving conditions.

An overvoltage warning may occur during deceleration if the load moment of inertia exceeds the allowable value. For servo drives with a built-in regenerative resistor, an overload alarm may be present. In case of such warnings, take one of the following measures:

- Reduce the torque limit values.
- Reduce the deceleration rate.
- Reduce the maximum speed.
- Install an external braking resistor if the warning cannot be cleared using the above measures.



Caution

- Drives below 400 W does not provide a built-in braking resistor.
- Even you use a built-in resistor, the energy generated in some conditions will exceed the allowable capacity loss (W) of the resistor. Therefore, an external braking resistor is required.

3.2.6 Ratio Characteristics for Allowable Load Moment of Inertia of Servo Unit Without Built-in Regenerative Resistor

The following diagrams show the allowable load moment of inertia scaling factor of the motor speed for servo units without built-in regenerative resistor when an external regenerative resistor is not connected. If the servo motor exceeds the allowable load moment of inertia, an overvoltage warning may occur in the servo unit.

The following figure provides reference data for deceleration at the rated torque or higher under 200 VAC input.

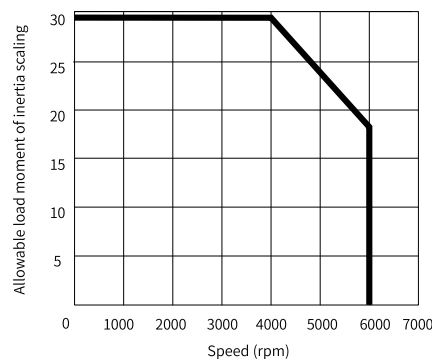

3.3 Selection Precautions

- The motor with oil seal must be derated by 10% during use.
- The brake cannot share the same power supply with other electrical devices. This is to prevent malfunction of the brake due to voltage or current drop caused by other working devices.
- Use cables with a cross-sectional area above 0.5 mm².

- Technical data and torque/speed characteristic values in the following tables are applicable to motors working with Inovance servo drives with the the armature coil temperature being 20°C.
- The characteristic parameter values are obtained in cases where the motor is installed with the following heatsink:
 - MS1H1/MS1H4: 250 × 250 × 6 (mm) (aluminum)
 - MS1H2-10C to 25C: 300 × 300 × 12 (mm) (aluminum)
 - MS1H2-30C to 50C: 400 × 400 × 20 (mm) (aluminum)
 - MS1H3-85B to 18C: 400 × 400 × 20 (mm) (iron)
 - MS1H3-29C to 75C: 360 × 360 × 25 (mm) (2-layer aluminum)
- Radial and axial loads of the motor

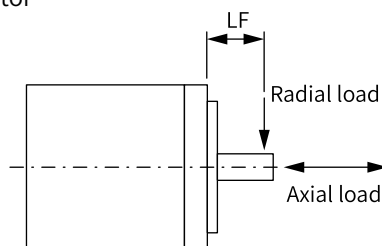
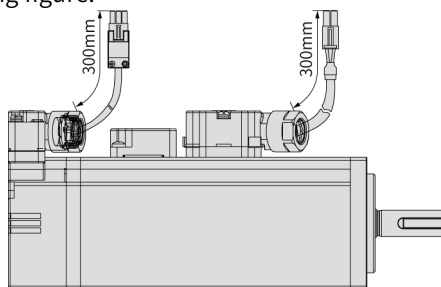

Figure 3-8 Radial and axial loads of the motor

- The tightening tension for terminal screws must be between 0.19 N·m to 0.21 N·m, exceeding of which may damage the terminal.
- Dimensions in the following dimension drawings are in millimeters (mm). Values inside brackets "()" are of the motor with a holding brake.
- Motor model ending with "-S4" represents the duty type S4, indicating the motor is working under S4 duty, with the motor load ratio not exceeding 70%.
- The 40/60/80-flange flying leads type motor (with "-S") provides a drain wire of about 300 mm long, as shown in the following figure.



3.4 Motor with Low Inertia and Small Capacity (MS1H1)

3.4.1 MS1H1-05B30CB-A33*Z(-S)

3.4.1.1

Motor Model		Torque-Speed characteristics	
Flange Size (mm)	40		
Inertia, Capacity	Low inertia, small capacity		
Rated Power (kW)	0.05		
Rated Voltage	220		
Rated torque (N·m)	0.16		
Maximum torque (N·m)	0.56		
Rated Current (Arms)	1.3		
Maximum Current (Arms)	4.70		
Rated speed (RPM)	3000		
Maximum speed (RPM)	6000		
Heatsink-based derating curve			
Torque coefficient (N·m/Arms)	0.15		
Rotor moment of inertia (kg·cm ²)	Motor without brake		0.026
	Motor with brake		0.028

Electrical specifications of the motor with brake

Holding Torque (N·m)	Supply Voltage (VDC) ±10%	Rated power (W)	Coil Resistance (Ω)(±7%)	Exciting Current (A)	Apply Time (ms)	Release Time (ms)	Backlash (°)
0.32	24	6.1	94.4	0.25	≤ 40	≤ 20	≤ 1.5

Allowable load

LF (mm)	Allowable Radial Load (N)	Allowed Axial Load (N)
20	78	54

Product dimensions (unit: mm)

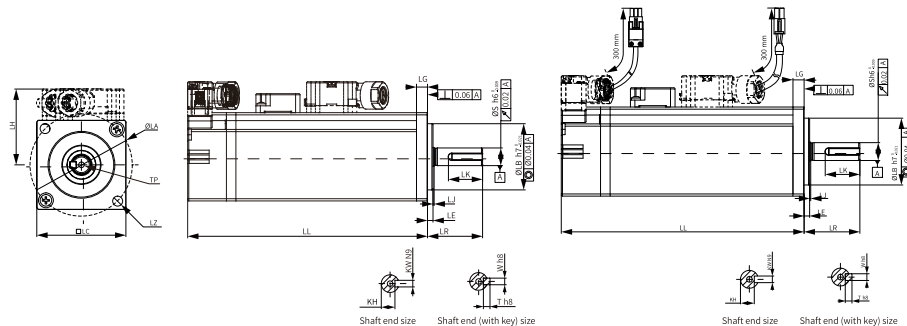

LL	LC	LR	LA	LZ	LH	LG	LE	LJ
65 (96)	40	25±0.5	46	2-Ø4.5	34	5	2.5±0.5	0.5±0.35
S	LB	TP	LK	KH	KW	W	T	Weight (kg)
8	30	M3x6	15.5	6.2- ⁰ 0.1	3	3	3	0.39 (0.50)

3.4.2 MS1H1-10B30CB-A33*Z(-S)

3.4.2.1

Motor Model		Torque-Speed characteristics		
Flange Size (mm)	40			
Inertia, Capacity	Low inertia, small capacity			
Rated Power (kW)	0.1			
Rated Voltage	220			
Rated torque (N·m)	0.32			
Maximum torque (N·m)	1.12			
Rated Current (Arms)	1.3			
Maximum Current (Arms)	4.70			
Rated speed (RPM)	3000			
Maximum speed (RPM)	6000			
Heatsink-based derating curve				
Torque coefficient (N·m/Arms)				0.26
Rotor moment of inertia (kg·cm ²)				Motor without brake
	Motor with brake	0.043		

Electrical specifications of the motor with brake

Holding Torque (N·m)	Supply Voltage (VDC) ±10%	Rated power (W)	Coil Resistance (Ω)(±7%)	Exciting Current (A)	Apply Time (ms)	Release Time (ms)	Backlash (°)
0.32	24	6.1	94.4	0.25	≤ 40	≤ 20	≤ 1.5

Allowable load

LF (mm)	Allowable Radial Load (N)	Allowed Axial Load (N)
20	78	54

Product dimensions (unit: mm)

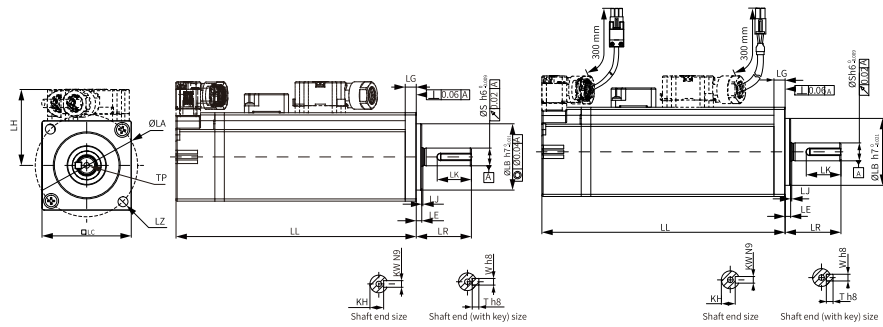

LL	LC	LR	LA	LZ	LH	LG	LE	LJ
77.5 (109)	40	25±0.5	46	2-Ø4.5	34	5	2.5±0.5	0.5±0.35
S	LB	TP	LK	KH	KW	W	T	Weight (kg)
8	30	M3x6	15.5	6.2- ⁰ 0.1	3	3	3	0.45 (0.64)

3.4.3 MS1H1-20B30CB-A33*Z(-S)

3.4.3.1

Motor Model		Torque-Speed characteristics		
Flange Size (mm)	60			
Inertia, Capacity	Low inertia, small capacity			
Rated Power (kW)	0.2			
Rated Voltage	220			
Rated torque (N·m)	0.64			
Maximum torque (N·m)	2.24			
Rated Current (Arms)	1.5	Heatsink-based derating curve		
Maximum Current (Arms)	5.80			
Rated speed (RPM)	3000			
Maximum speed (RPM)	6000			
Torque coefficient (N·m/Arms)	0.46			
Rotor moment of inertia (kg·cm ²)	Motor without brake			0.207
	Motor with brake			0.22

Electrical specifications of the motor with brake

Holding Torque (N·m)	Supply Voltage (VDC) ±10%	Rated power (W)	Coil Resistance (Ω)(±7%)	Exciting Current (A)	Apply Time (ms)	Release Time (ms)	Backlash (°)
1.5	24	7.6	75.79	0.32	≤ 60	≤ 20	≤ 1.5

Allowable load

LF (mm)	Allowable Radial Load (N)	Allowed Axial Load (N)
25	245	74

Product dimensions (unit: mm)

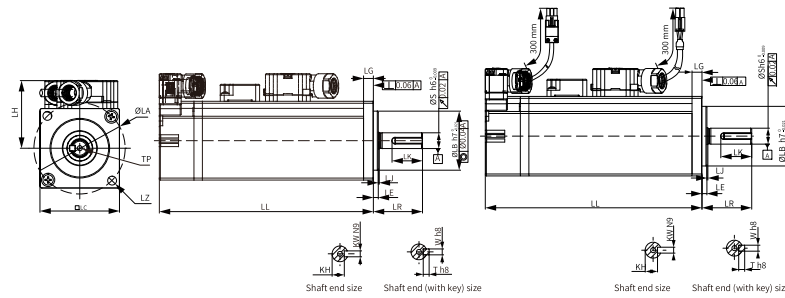

LL	LC	LR	LA	LZ	LH	LG	LE	LJ
72.5 (100)	60	30±0.5	70	4-Ø5.5	44	7.5	3±0.5	0.5±0.35
S	LB	TP	LK	KH	KW	W	T	Weight (kg)
14	50	M5x8	16.5	11- ⁰ 0.1	5	5	5	0.78 (1.16)

3.4.4 MS1H1-40B30CB-A33*Z(-S)

3.4.4.1

Motor Model		Torque-Speed characteristics
Flange Size (mm)	60	<p>— A Continuous working area — B Short term working area</p>
Inertia, Capacity	Low inertia, small capacity	
Rated Power (kW)	0.2	
Rated Voltage	220	
Rated torque (N·m)	1.27	
Maximum torque (N·m)	4.46	Heatsink-based derating curve
Rated Current (Arms)	2.8	
Maximum Current (Arms)	10.1	
Rated speed (RPM)	3000	
Maximum speed (RPM)	6000	
Torque coefficient (N·m/Arms)	0.53	
Rotor moment of inertia (kg·cm ²)	Motor without brake	0.376
	Motor with brake	0.39

Electrical specifications of the motor with brake

Holding Torque (N·m)	Supply Voltage (VDC) ±10%	Rated power (W)	Coil Resistance (Ω)(±7%)	Exciting Current (A)	Apply Time (ms)	Release Time (ms)	Backlash (°)
1.5	24	7.6	75.79	0.32	≤ 60	≤ 20	≤ 1.5

Allowable load

LF (mm)	Allowable Radial Load (N)	Allowed Axial Load (N)
25	245	74

Product dimensions (unit: mm)

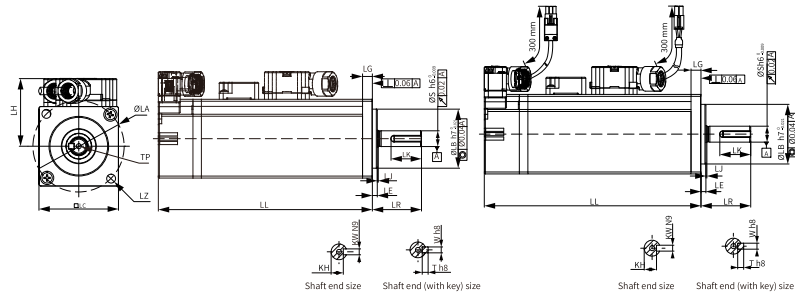

LL	LC	LR	LA	LZ	LH	LG	LE	LJ
91 (119)	60	30±0.5	70	4-Ø5.5	44	7.5	3±0.5	0.5±0.35
S	LB	TP	LK	KH	KW	W	T	Weight (kg)
14	50	M5x8	16.5	11- ⁰ 0.1	5	5	5	1.11 (1.48)

3.4.5 MS1H1-55B30CB-A331Z(-S)

3.4.5.1

Motor Model		Torque-Speed characteristics
Flange Size (mm)	80	
Inertia, Capacity	Low inertia, small capacity	
Rated Power (kW)	0.55	
Rated Voltage	220	
Rated torque (N·m)	1.75	
Maximum torque (N·m)	6.13	
Rated Current (Arms)	3.8	Heatsink-based derating curve
Maximum Current (Arms)	15	
Rated speed (RPM)	3000	
Maximum speed (RPM)	6000	
Torque coefficient (N·m/Arms)	0.49	
Rotor moment of inertia (kg·cm ²)	1.06	

Allowable load

LF (mm)	Allowable Radial Load (N)	Allowed Axial Load (N)
35	392	147

Product dimensions (unit: mm)

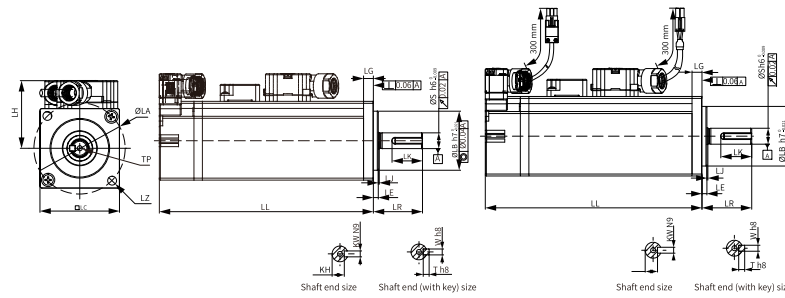

LL	LC	LR	LA	LZ	LH	LG	LE	LJ
96.2	80	35±0.5	90	4-Ø7	54	7.7	3±0.5	0.5±0.35
S	LB	TP	LK	KH	KW	W	T	Weight (kg)
19	70	M6×20	25	15.5- ⁰ 0.1	6	6	6	1.85

3.4.6 MS1H1-75B30CB-A33*Z(-S)

3.4.6.1

Motor Model		Torque-Speed characteristics	
Flange Size (mm)	80		
Inertia, Capacity	Low inertia, small capacity		
Rated Power (kW)	0.75		
Rated Voltage	220		
Rated torque (N·m)	2.39		
Maximum torque (N·m)	8.36		
Rated Current (Arms)	4.8	Heatsink-based derating curve	
Maximum Current (Arms)	16.9		
Rated speed (RPM)	3000		
Maximum speed (RPM)	6000		
Torque coefficient (N·m/Arms)	0.58		
Rotor moment of inertia (kg·cm ²)	Motor without brake		1.38
	Motor with brake		1.43

Electrical specifications of the motor with brake

Holding Torque (N·m)	Supply Voltage (VDC) ±10%	Rated power (W)	Coil Resistance (Ω)(±7%)	Exciting Current (A)	Apply Time (ms)	Release Time (ms)	Backlash (°)
3.2	24	10	57.6	0.42	≤ 60	≤ 40	≤ 1

Allowable load

LF (mm)	Allowable Radial Load (N)	Allowed Axial Load (N)
35	392	147

Product dimensions (unit: mm)

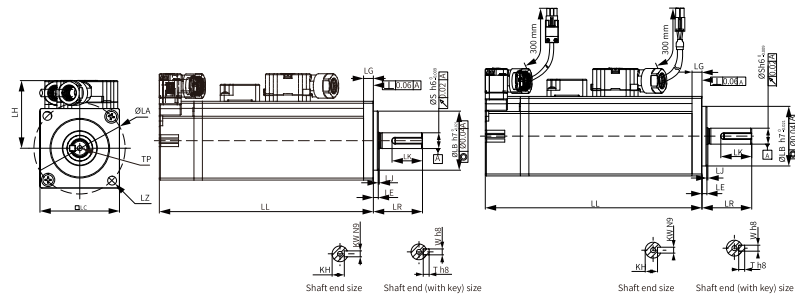

LL	LC	LR	LA	LZ	LH	LG	LE	LJ
107 (140)	80	35±0.5	90	4-Ø7	54	7.7	3±0.5	0.5±0.35
S	LB	TP	LK	KH	KW	W	T	Weight (kg)
19	70	M6×20	25	15.5- ⁰ 0.1	6	6	6	2.18 (2.82)

3.4.7 MS1H1-10C30CB-A331Z(-S)

3.4.7.1

Motor Model		Torque-Speed characteristics		
Flange Size (mm)	80			
Inertia, Capacity	Low inertia, small capacity			
Rated Power (kW)	1.0			
Rated Voltage	220			
Rated torque (N·m)	3.18			
Maximum torque (N·m)	11.1			
Rated Current (Arms)	7.6			
Maximum Current (Arms)	28			
Rated speed (RPM)	3000			
Maximum speed (RPM)	6000			
Torque coefficient (N·m/Arms)	0.46			
Rotor moment of inertia (kg·cm ²)	Motor without brake			1.75
	Motor with brake			1.86

Electrical specifications of the motor with brake

Holding Torque (N·m)	Supply Voltage (VDC) ±10%	Rated power (W)	Coil Resistance (Ω)(±7%)	Exciting Current (A)	Apply Time (ms)	Release Time (ms)	Backlash (°)
3.2	24	10	57.6	0.42	≤ 60	≤ 40	≤ 1

Allowable load

LF (mm)	Allowable Radial Load (N)	Allowed Axial Load (N)
35	392	147

Product dimensions (unit: mm)

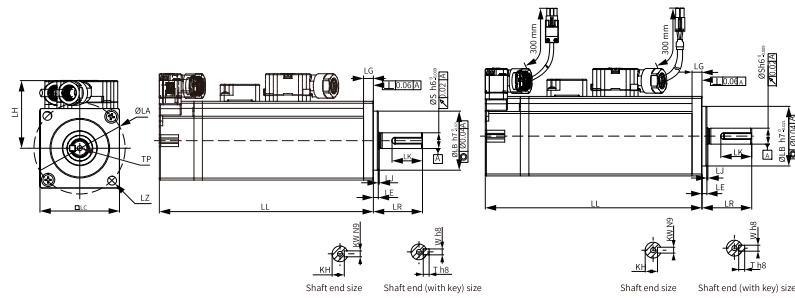

LL	LC	LR	LA	LZ	LH	LG	LE	LJ
118.2	80	35±0.5	90	4-Ø7	54	7.7	3±0.5	0.5±0.35
S	LB	TP	LK	KH	KW	W	T	Weight (kg)
19	70	M6×20	25	15.5- ⁰ 0.1	6	6	6	2.55

3.5 Motor with Low Inertia and Medium Capacity (MS1H2)

3.5.1 MS1H2-10C30CB-A33*Z

3.5.1.1

Motor Model		Torque-Speed characteristics
Flange Size (mm)	100	
Inertia, Capacity	Low inertia, medium capacity	
Rated Power (kW)	1.0	
Rated Voltage	220	
Rated torque (N·m)	3.18	
Maximum torque (N·m)	9.54	
Rated Current (Arms)	7.5	
Maximum Current (Arms)	23	
Rated speed (RPM)	3000	
Maximum speed (RPM)	6000	
Torque coefficient (N·m/Arms)	0.47	Heatsink-based derating curve
Rotor moment of inertia (kg·cm ²)	Motor without brake	1.87
	Motor with brake	3.12

Electrical specifications of the motor with brake

Holding Torque (N·m)	Supply Voltage (VDC) ±10%	Rated power (W)	Coil Resistance (Ω)(±7%)	Exciting Current (A)	Apply Time (ms)	Release Time (ms)	Backlash (°)
8	24	23	25	0.96	≤ 85	≤ 30	≤ 0.5

Allowable load

LF (mm)	Allowable Radial Load (N)	Allowed Axial Load (N)
45	686	196

Product dimensions (unit: mm)

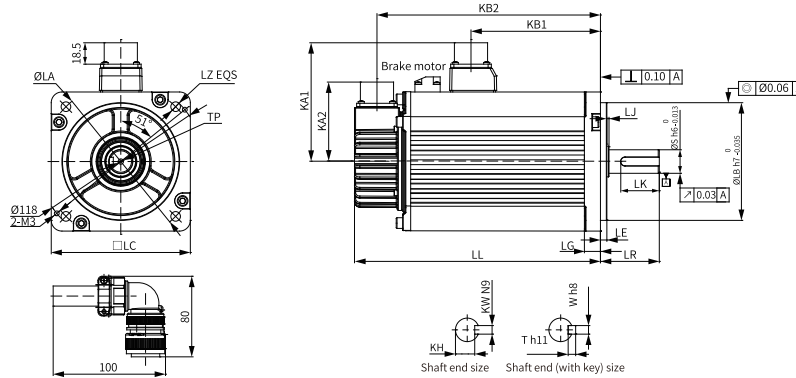

LL	LC	LE	LA	LZ	KA1	KA2	LJ		KB1	KB2	
164 (213.5)	100	5±0.3	115	4-Ø7	88	74	2.5±0.75		94.5 (101)	143.5 (192.5)	
LR		S	LB	TP	LK	KH	KW	W	T	LG	Weight (kg)
45±1		24	95	M8×16	36	20 ⁰ _{-0.2}	8	8	7	10	5.11 (6.41)

3.5.2 MS1H2-10C30CD-A33*Z

3.5.2.1

Motor Model			Torque-Speed characteristics	
Flange Size (mm)	100			
Inertia, Capacity	Low inertia, medium capacity			
Rated Power (kW)	1			
Rated Voltage	380			
Rated torque (N·m)	3.18			
Maximum torque (N·m)	9.54			
Rated Current (Arms)	3.65			
Maximum Current (Arms)	11			
Rated speed (RPM)	3000			
Maximum speed (RPM)	6000			
Torque coefficient (N·m/Arms)	0.89			
Rotor moment of inertia (kg·cm ²)	Motor without brake	1.87		
	Motor with brake	3.12		

Electrical specifications of the motor with brake

Holding Torque (N·m)	Supply Voltage (VDC) ±10%	Rated power (W)	Coil Resistance (Ω)(±7%)	Exciting Current (A)	Apply Time (ms)	Release Time (ms)	Backlash (°)
8	24	23	25	0.96	≤ 85	≤ 30	≤ 0.5

Allowable load

LF (mm)	Allowable Radial Load (N)	Allowed Axial Load (N)
45	686	196

Product dimensions (unit: mm)

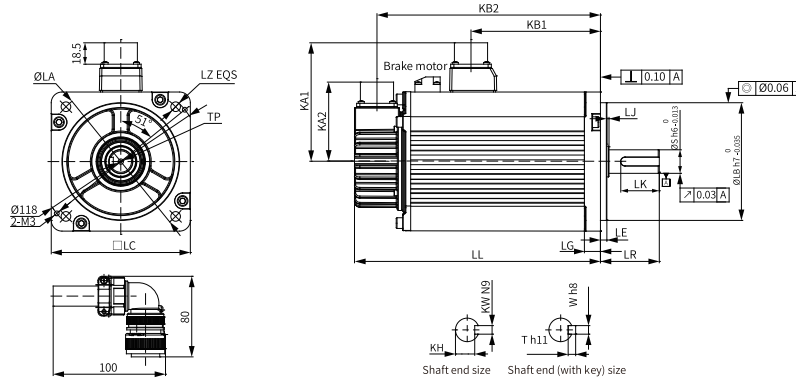

LL	LC	LE	LA	LZ	KA1	KA2	LJ	KB1	KB2	
164 (213.5)	100	5±0.3	115	4-Ø7	88	74	2.5±0.75	94.5 (101)	143.5 (192.5)	
LR	S	LB	TP	LK	KH	KW	W	T	LG	Weight (kg)
45±1	24	95	M8×16	36	20 ⁰ -0.2	8	8	7	10	5.11 (6.41)

3.5.3 MS1H2-15C30CB-A33*Z

3.5.3.1

Motor Model		Torque-Speed characteristics		
Flange Size (mm)	100			
Inertia, Capacity	Low inertia, medium capacity			
Rated Power (kW)	1.5			
Rated Voltage	220			
Rated torque (N·m)	4.9			
Maximum torque (N·m)	14.7			
Rated Current (Arms)	10.8	Heatsink-based derating curve		
Maximum Current (Arms)	32			
Rated speed (RPM)	3000			
Maximum speed (RPM)	5000			
Torque coefficient (N·m/Arms)	0.54			
Rotor moment of inertia (kg·cm ²)	Motor without brake			2.46
	Motor with brake			3.71

Electrical specifications of the motor with brake

Holding Torque (N·m)	Supply Voltage (VDC) ±10%	Rated power (W)	Coil Resistance (Ω)(±7%)	Exciting Current (A)	Apply Time (ms)	Release Time (ms)	Backlash (°)
8	24	23	25	0.96	≤ 85	≤ 30	≤ 0.5

Allowable load

LF (mm)	Allowable Radial Load (N)	Allowed Axial Load (N)
45	686	196

Product dimensions (unit: mm)

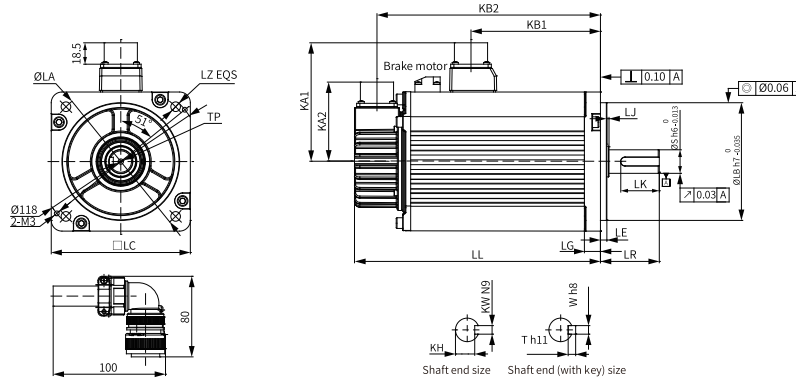

LL	LC	LE	LA	LZ	KA1	KA2	LJ	KB1	KB2	
189 (239)	100	5±0.3	115	4-Ø7	88	74	2.5±0.75	119.5 (128)	168.5 (219.5)	
LR	S	LB	TP	LK	KH	KW	W	T	LG	Weight (kg)
45±1	24	95	M8×16	36	20 ⁰ -0.2	8	8	7	10	6.22 (7.52)

3.5.4 MS1H2-15C30CD-A33*Z

3.5.4.1

Motor Model		Torque-Speed characteristics		
Flange Size (mm)	100			
Inertia, Capacity	Low inertia, medium capacity			
Rated Power (kW)	1.5			
Rated Voltage	380			
Rated torque (N·m)	4.9			
Maximum torque (N·m)	14.7			
Rated Current (Arms)	4.5			
Maximum Current (Arms)	14			
Rated speed (RPM)	3000			
Maximum speed (RPM)	5000			
Torque coefficient (N·m/Arms)	1.07			
Rotor moment of inertia (kg·cm ²)	Motor without brake			2.46
	Motor with brake			3.71

Electrical specifications of the motor with brake

Holding Torque (N·m)	Supply Voltage (VDC) ±10%	Rated power (W)	Coil Resistance (Ω)(±7%)	Exciting Current (A)	Apply Time (ms)	Release Time (ms)	Backlash (°)
8	24	23	25	0.96	≤ 85	≤ 30	≤ 0.5

Allowable load

LF (mm)	Allowable Radial Load (N)	Allowed Axial Load (N)
45	686	196

Product dimensions (unit: mm)

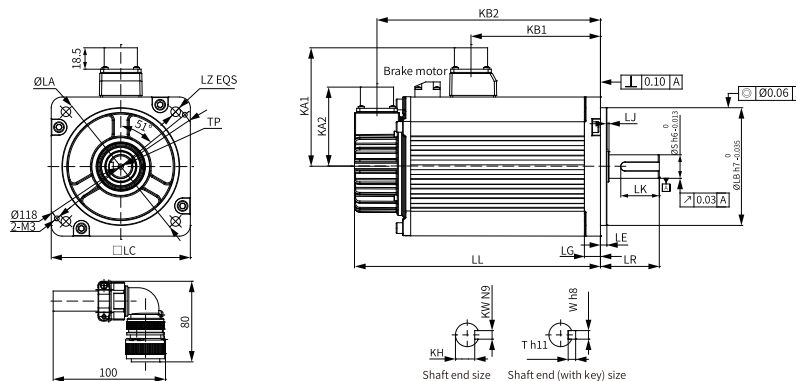

LL	LC	LE	LA	LZ	KA1	KA2	LJ		KB1	KB2	
189 (239)	100	5 ± 0.3	115	$4-\varnothing 7$	88	74	2.5 ± 0.75		119.5 (128)	168.5 (219.5)	
LR		S	LB	TP	LK	KH	KW	W	T	LG	Weight (kg)
45 ± 1		24	95	$M8 \times 16$	36	$20^0_{-0.2}$	8	8	7	10	6.22 (7.52)

3.5.5 MS1H2-20C30CD-A331Z

3.5.5.1

Motor Model		Torque-Speed characteristics
Flange Size (mm)	100	<p>— A Continuous working area — B Short term working area</p>
Inertia, Capacity	Low inertia, medium capacity	
Rated Power (kW)	2	
Rated Voltage	380	
Rated torque (N·m)	6.36	
Maximum torque (N·m)	19.1	
Rated Current (Arms)	5.89	Heatsink-based derating curve
Maximum Current (Arms)	20	
Rated speed (RPM)	3000	
Maximum speed (RPM)	5000	
Torque coefficient (N·m/Arms)	1.19	
Rotor moment of inertia ($kg \cdot cm^2$)	3.06	

Allowable load

LF (mm)	Allowable Radial Load (N)	Allowed Axial Load (N)
45	686	196

Product dimensions (unit: mm)

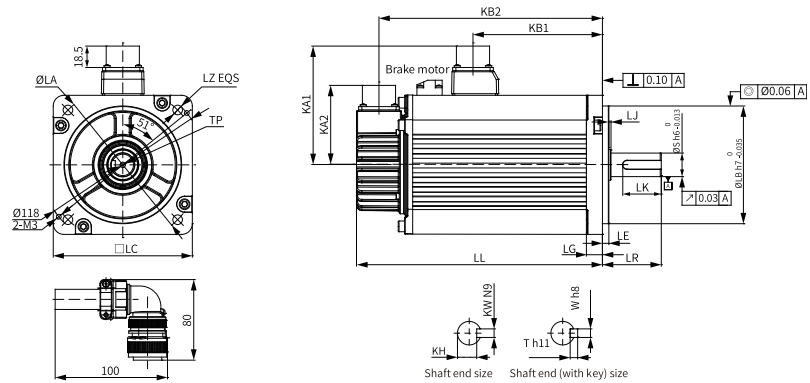

LL	LC	LE	LA	LZ	KA1	KA2	LJ		KB1	KB2	
214	100	5±0.3	115	4-Ø7	88	74	2.5±0.75		144.5	193.5	
LR		S	LB	TP	LK	KH	KW	W	T	LG	Weight (kg)
45±1		24	95	M8×16	36	20 ⁰ _{-0.2}	8	8	7	10	7.39

3.5.6 MS1H2-20C30CD-A334Z-S4

3.5.6.1

Motor Model		Torque-Speed characteristics
Flange Size (mm)	100	
Inertia, Capacity	Low inertia, medium capacity	
Rated Power (kW)	2	
Rated Voltage	380	
Rated torque (N·m)	6.36	
Maximum torque (N·m)	19.1	
Rated Current (Arms)	5.89	Heatsink-based derating curve
Maximum Current (Arms)	20	
Rated speed (RPM)	3000	
Maximum speed (RPM)	5000	
Torque coefficient (N·m/Arms)	1.19	
Rotor moment of inertia (kg·cm ²)	4.31	

Electrical specifications of the motor with brake

Holding Torque (N·m)	Supply Voltage (VDC) ±10%	Rated power (W)	Coil Resistance (Ω)(±7%)	Exciting Current (A)	Apply Time (ms)	Release Time (ms)	Backlash (°)
8	24	23	25	0.96	≤ 85	≤ 30	≤ 0.5

Allowable load

LF (mm)	Allowable Radial Load (N)	Allowed Axial Load (N)
45	686	196

Product dimensions (unit: mm)

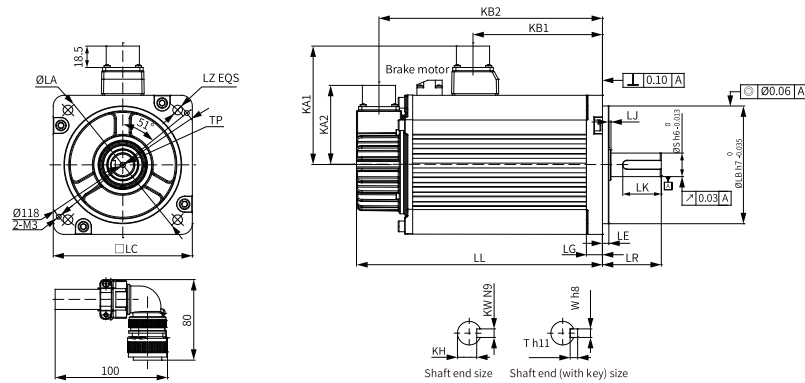

LL	LC	LE	LA	LZ	KA1	KA2	KW	LG	KB1	KB2	
265	100	5±0.3	115	4-Ø7	88	74	8	10	153	244	
LR		S	LB	TP	LK	KH	LJ		W	T	Weight (kg)
45±1		24	95	M8×16	36	20 ⁰ _{-0.2}	2.5±0.75		8	7	8.7

3.5.7 MS1H2-25C30CD-A331Z

3.5.7.1

Motor Model		Torque-Speed characteristics
Flange Size (mm)	100	<p>The graph plots Speed (rpm) on the y-axis (0 to 6000) against Torque (N·m) on the x-axis (0 to 25). Area A (red) is the continuous working area, and Area B (blue) is the short-term working area. Area A is bounded by a vertical line at 7.96 N·m and a curve that starts at 5000 rpm at 7.96 N·m and drops to 3000 rpm at 23.9 N·m. Area B is bounded by a vertical line at 23.9 N·m and a curve that starts at 5000 rpm at 23.9 N·m and drops to 3000 rpm at 25 N·m.</p>
Inertia, Capacity	Low inertia, medium capacity	
Rated Power (kW)	2.5	
Rated Voltage	380	
Rated torque (N·m)	7.96	
Maximum torque (N·m)	23.9	
Rated Current (Arms)	7.56	Heatsink-based derating curve
Maximum Current (Arms)	25	<p>The graph plots Rating reduction (%) on the y-axis (0 to 120) against Heatsink size (mm) on the x-axis (0 to 350). The curve shows a linear increase in rating reduction from approximately 55% at 100 mm to 100% at 300 mm.</p>
Rated speed (RPM)	3000	
Maximum speed (RPM)	5000	
Torque coefficient (N·m/Arms)	1.2	
Rotor moment of inertia (kg·cm ²)	3.65	

Allowable load

LF (mm)	Allowable Radial Load (N)	Allowed Axial Load (N)
45	686	196

Product dimensions (unit: mm)

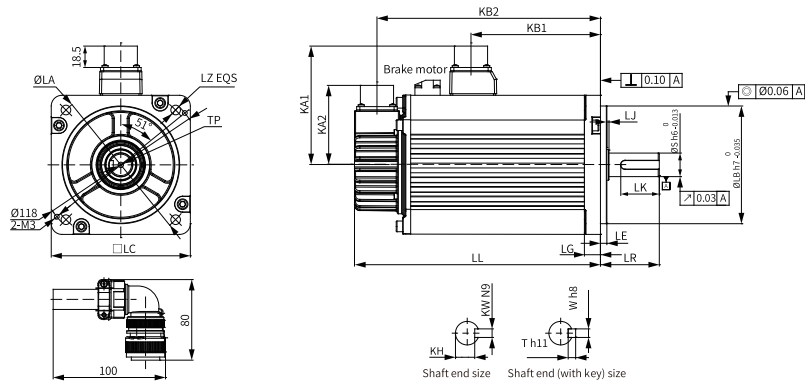

LL	LC	LE	LA	LZ	KA1	KA2	KW	LG	KB1	KB2
240.5	100	5±0.3	115	4-Ø7	88	74	8	10	169.5	218.5
LR	S	LB	TP	LK	KH	LJ	W	T	Weight (kg)	
45±1	24	95	M8×16	36	20 ⁰ _{-0.2}	2.5±0.75	8	7	8.55	

3.5.8 MS1H2-25C30CD-A334Z-S4

3.5.8.1

Motor Model		Torque-Speed characteristics
Flange Size (mm)	100	
Inertia, Capacity	Low inertia, medium capacity	
Rated Power (kW)	2.5	
Rated Voltage	380	
Rated torque (N·m)	7.96	
Maximum torque (N·m)	23.9	
Rated Current (Arms)	7.56	Heatsink-based derating curve
Maximum Current (Arms)	25	
Rated speed (RPM)	3000	
Maximum speed (RPM)	5000	
Torque coefficient (N·m/Arms)	1.2	
Rotor moment of inertia (kg·cm ²)	4.9	

Electrical specifications of the motor with brake

Holding Torque (N·m)	Supply Voltage (VDC) ±10%	Rated power (W)	Coil Resistance (Ω)(±7%)	Exciting Current (A)	Apply Time (ms)	Release Time (ms)	Backlash (°)
8	24	23	25	0.96	≤ 85	≤ 30	≤ 0.5

Allowable load

LF (mm)	Allowable Radial Load (N)	Allowed Axial Load (N)
45	686	196

Product dimensions (unit: mm)

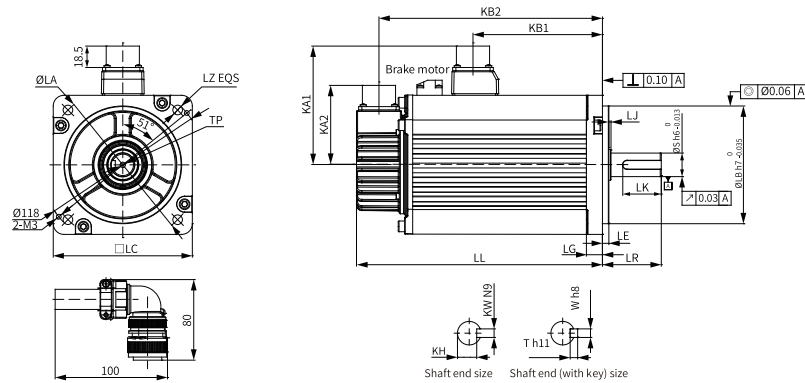

LL	LC	LE	LA	LZ	KA1	KA2	KW	LG	KB1	KB2	
290	100	5±0.3	115	4-Ø7	88	74	8	10	178	269	
LR		S	LB	TP	LK	KH	LJ		W	T	Weight (kg)
45±1		24	95	M8×16	36	20 ⁰ _{-0.2}	2.5±0.75		8	7	9.8

3.5.9 MS1H2-30C30CD-A331Z

3.5.9.1

Motor Model		Torque-Speed characteristics
Flange Size (mm)	130	<p>The graph plots Speed (rpm) on the y-axis (0 to 6000) against Torque (N·m) on the x-axis (0 to 30). Area A (red) is the continuous working area, and Area B (blue) is the short-term working area. Area A is bounded by a horizontal line at 5000 rpm from 0 to 12 N·m, and a curve from (12, 5000) to (30, 3000). Area B is bounded by a horizontal line at 3000 rpm from 12 to 30 N·m, and a curve from (12, 5000) to (30, 3000).</p>
Inertia, Capacity	Low inertia, medium capacity	
Rated Power (kW)	3	
Rated Voltage	380	
Rated torque (N·m)	9.8	
Maximum torque (N·m)	29.4	
Rated Current (Arms)	10	Heatsink-based derating curve
Maximum Current (Arms)	30	<p>The graph plots Rating reduction (%) on the y-axis (0 to 120) against Heatsink size (mm) on the x-axis (100 to 450). The curve shows that as the heatsink size increases, the rating reduction percentage also increases, starting at approximately 35% for a 100mm heatsink and reaching 100% for a 450mm heatsink.</p>
Rated speed (RPM)	3000	
Maximum speed (RPM)	5000	
Torque coefficient (N·m/Arms)	1.2	
Rotor moment of inertia (kg·cm ²)	7.72	

Allowable load

LF (mm)	Allowable Radial Load (N)	Allowed Axial Load (N)
63	980	392

Product dimensions (unit: mm)

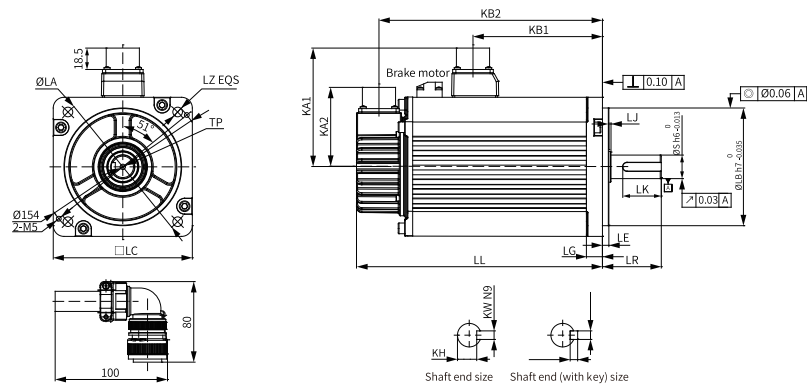

LL	LC	LE	LA	LZ	KA1	KA2	KW	LG	KB1	KB2	
290.5	130	6±0.3	145	4-Ø9	103	74	8	14	136	188.5	
LR		S	LB	TP	LK	KH	LJ		W	T	Weight (kg)
63±1		28	110	M8×20	54	24 ⁰ _{-0.2}	0.5±0.75		8	7	10.73

3.5.10 MS1H2-30C30CD-A334Z-S4

3.5.10.1

Motor Model		Torque-Speed characteristics
Flange Size (mm)	130	
Inertia, Capacity	Low inertia, medium capacity	
Rated Power (kW)	3	
Rated Voltage	380	
Rated torque (N·m)	9.8	
Maximum torque (N·m)	29.4	
Rated Current (Arms)	10	
Maximum Current (Arms)	30	
Rated speed (RPM)	3000	
Maximum speed (RPM)	5000	
Torque coefficient (N·m/Arms)	1.2	
Rotor moment of inertia (kg·cm ²)	10.22	

Electrical specifications of the motor with brake

Holding Torque (N·m)	Supply Voltage (VDC) ±10%	Rated power (W)	Coil Resistance (Ω)(±7%)	Exciting Current (A)	Apply Time (ms)	Release Time (ms)	Backlash (°)
16	24	27	21.3	1.13	≤ 100	≤ 60	≤ 0.5

Allowable load

LF (mm)	Allowable Radial Load (N)	Allowed Axial Load (N)
63	980	392

Product dimensions (unit: mm)

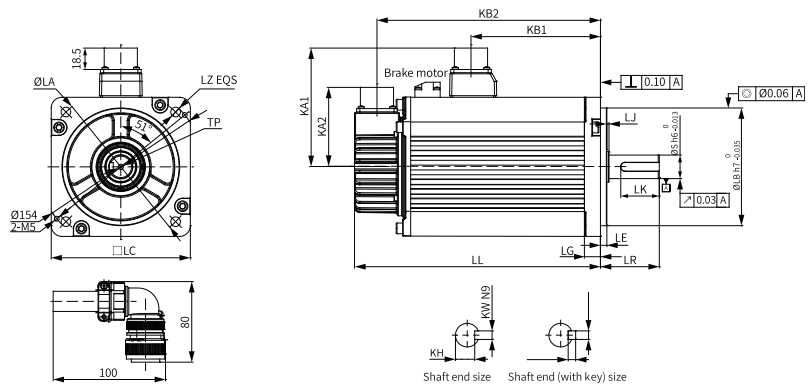

LL	LC	LE	LA	LZ	KA1	KA2	KW	LG	KB1	KB2	
265.5	130	6±0.3	145	4-Ø9	103	74	8	14	139	244.5	
LR		S	LB	TP	LK	KH	LJ		W	T	Weight (kg)
63±1		28	110	M8×20	54	24 ⁰ _{-0.2}	0.5±0.75		8	7	13.2

3.5.11 MS1H2-40C30CD-A331Z

3.5.11.1

Motor Model		Torque-Speed characteristics
Flange Size (mm)	130	
Inertia, Capacity	Low inertia, medium capacity	
Rated Power (kW)	4	
Rated Voltage	380	
Rated torque (N·m)	12.6	
Maximum torque (N·m)	37.8	
Rated Current (Arms)	13.6	
Maximum Current (Arms)	40.8	
Rated speed (RPM)	3000	
Maximum speed (RPM)	5000	
Torque coefficient (N·m/Arms)	1.12	
Rotor moment of inertia (kg·cm ²)	12.1	

Allowable load

LF (mm)	Allowable Radial Load (N)	Allowed Axial Load (N)
63	1176	392

Product dimensions (unit: mm)

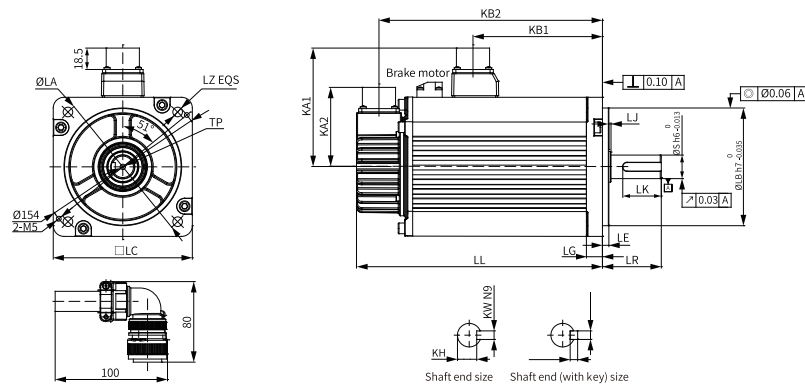

LL	LC	LE	LA	LZ	KA1	KA2	KW	LG	KB1	KB2	
252	130	6±0.3	145	4-Ø9	103	74	8	14	178.5	231	
LR		S	LB	TP	LK	KH	LJ		W	T	Weight (kg)
63±1		28	110	M8×20	54	24 ⁰ _{-0.2}	0.5±0.75		8	7	15.43

3.5.12 MS1H2-40C30CD-A334Z-S4

3.5.12.1

Motor Model		Torque-Speed characteristics
Flange Size (mm)	130	
Inertia, Capacity	Low inertia, medium capacity	
Rated Power (kW)	4	
Rated Voltage	380	
Rated torque (N·m)	12.6	
Maximum torque (N·m)	37.8	
Rated Current (Arms)	13.6	
Maximum Current (Arms)	40.8	
Rated speed (RPM)	3000	
Maximum speed (RPM)	5000	
Torque coefficient (N·m/Arms)	1.12	
Rotor moment of inertia (kg·cm ²)	14.6	

Electrical specifications of the motor with brake

Holding Torque (N·m)	Supply Voltage (VDC) ±10%	Rated power (W)	Coil Resistance (Ω)(±7%)	Exciting Current (A)	Apply Time (ms)	Release Time (ms)	Backlash (°)
16	24	27	21.3	1.13	≤ 100	≤ 60	≤ 0.5

Allowable load

LF (mm)	Allowable Radial Load (N)	Allowed Axial Load (N)
63	1176	392

Product dimensions (unit: mm)

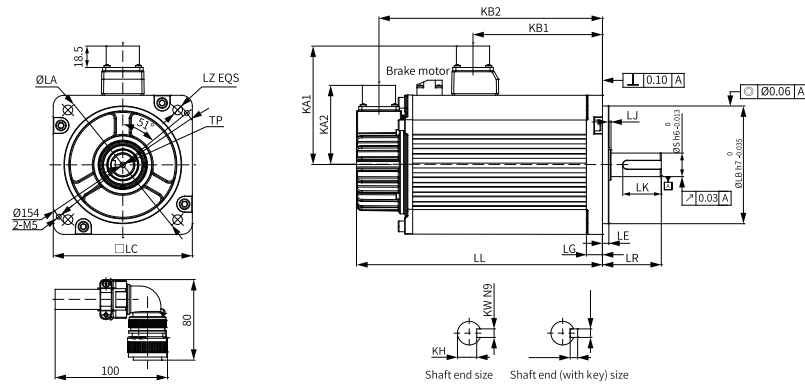

LL	LC	LE	LA	LZ	KA1	KA2	KW	LG	KB1	KB2	
308	130	6±0.3	145	4-Ø9	103	74	8	14	181.5	287	
LR		S	LB	TP	LK	KH	LJ		W	T	Weight (kg)
63±1		28	110	M8×20	54	24 ⁰ _{-0.2}	0.5±0.75		8	7	17.9

3.5.13 MS1H2-50C30CD-A331Z

3.5.13.1

Motor Model		Torque-Speed characteristics
Flange Size (mm)	130	<p>The graph plots Speed (rpm) on the y-axis (0 to 6000) against Torque (N·m) on the x-axis (0 to 50). Area A (red) is the continuous working area, and Area B (blue) is the short-term working area. Area A is bounded by a vertical line at ~15 N·m and a curve. Area B is bounded by a vertical line at ~45 N·m and a curve.</p>
Inertia, Capacity	Low inertia, medium capacity	
Rated Power (kW)	5	
Rated Voltage	380	
Rated torque (N·m)	15.8	
Maximum torque (N·m)	47.4	
Rated Current (Arms)	16	
Maximum Current (Arms)	48	
Rated speed (RPM)	3000	
Maximum speed (RPM)	5000	
Torque coefficient (N·m/Arms)	1.29	
Rotor moment of inertia (kg·cm ²)	15.4	
		Heatsink-based derating curve
		<p>The graph plots Rating reduction (%) on the y-axis (0 to 120) against Heatsink size (mm) on the x-axis (100 to 450). The curve shows that as the heatsink size increases, the rating reduction percentage also increases, starting from 0% at 100mm and reaching approximately 100% at 450mm.</p>

Allowable load

LF (mm)	Allowable Radial Load (N)	Allowed Axial Load (N)
63	1176	392

Product dimensions (unit: mm)

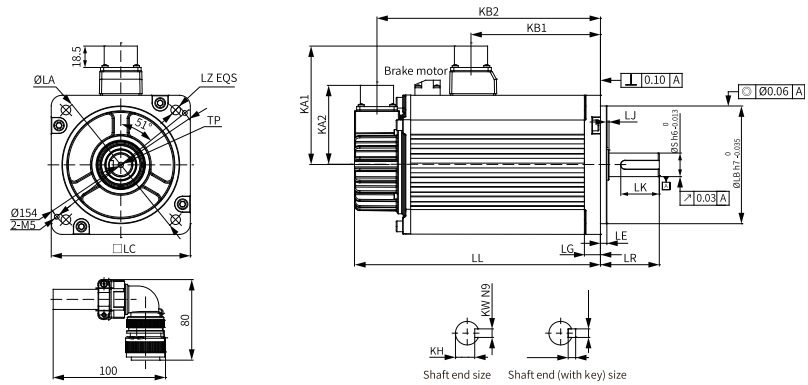

LL	LC	LE	LA	LZ	KA1	KA2	KW	LG	KB1	KB2	
294.5	130	6±0.3	145	4-Ø9	103	74	8	14	221	273.5	
LR		S	LB	TP	LK	KH	LJ		W	T	Weight (kg)
63±1		28	110	M8×20	54	24 ⁰ _{-0.2}	0.5±0.75		8	7	16.2

3.5.14 MS1H2-50C30CD-A334Z-S4

3.5.14.1

Motor Model		Torque-Speed characteristics
Flange Size (mm)	130	
Inertia, Capacity	Low inertia, medium capacity	
Rated Power (kW)	5	
Rated Voltage	380	
Rated torque (N·m)	15.8	
Maximum torque (N·m)	47.4	
Rated Current (Arms)	16	
Maximum Current (Arms)	48	
Rated speed (RPM)	3000	
Maximum speed (RPM)	5000	
Torque coefficient (N·m/Arms)	1.29	
Rotor moment of inertia (kg·cm ²)	17.9	

Electrical specifications of the motor with brake

Holding Torque (N·m)	Supply Voltage (VDC) ±10%	Rated power (W)	Coil Resistance (Ω)(±7%)	Exciting Current (A)	Apply Time (ms)	Release Time (ms)	Backlash (°)
16	24	27	21.3	1.13	≤ 100	≤ 60	≤ 0.5

Allowable load

LF (mm)	Allowable Radial Load (N)	Allowed Axial Load (N)
63	1176	392

Product dimensions (unit: mm)

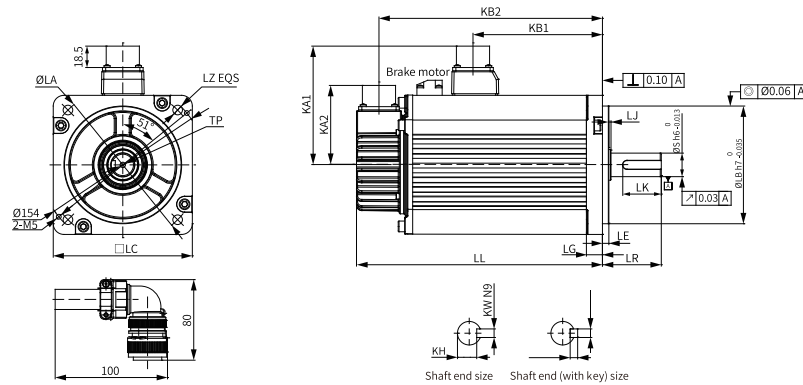

LL	LC	LE	LA	LZ	KA1	KA2	KW	LG	KB1	KB2	
350.5	130	6±0.3	145	4-Ø9	103	74	8	14	224	329.5	
LR		S	LB	TP	LK	KH	LJ		W	T	Weight (kg)
63±1		28	110	M8×20	54	24 ⁰ _{-0.2}	0.5±0.75		8	7	18.4

3.6 Motor with Medium Inertia and Medium Capacity (MS1H3)

3.6.1 MS1H3-85B15CB-A33*Z

3.6.1.1

Motor Model		Torque-Speed characteristics		
Flange Size (mm)	130			
Inertia, Capacity	Medium inertia, medium capacity			
Rated output (kW)	0.85			
Voltage (V)	220			
Rated torque (N·m)	5.39			
Maximum torque (N·m)	13.5			
Rated Current (Arms)	6.6			
Maximum Current (Arms)	16.5			
Rated speed (RPM)	1500			
Maximum speed (RPM)	3000			
Torque coefficient (N·m/Arms)	0.95			
Rotor moment of inertia (kg·cm ²)	Motor without brake			13.3
	Motor with brake			14

Electrical specifications of the motor with brake

Holding torque (N·m)	Supply Voltage (V DC)±10%	Rated Power (W)	Coil Resistance (Ω) (±7%)	Exciting Current (A)	Apply Time (ms)	Release Time (ms)	Backlash (°)
12	24	19.4	29.7	0.81	≤ 120	≤ 60	≤ 0.5

Allowable load

LF (mm)	Allowable Radial Load (N)	Allowed Axial Load (N)
45	686	196

Product dimensions (unit: mm)

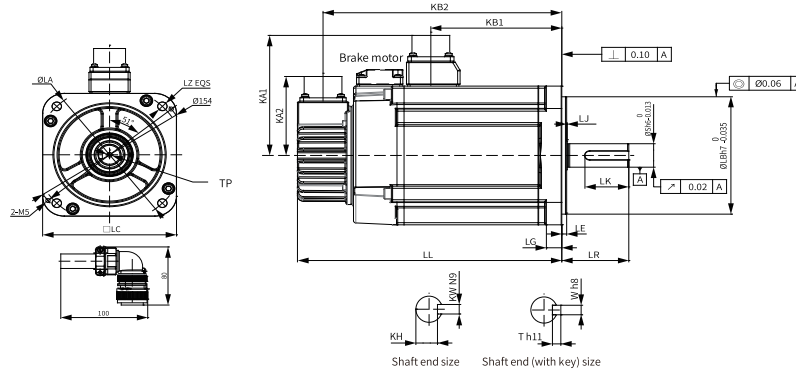

LL	LC	LE	LA	LZ	KA1	KB1	KA2	KB2	LG	kW
146 (182)	130	4	145	4-Ø9	103	72.5	74	125 (161)	14	8
LR	S	LB	TP	LK	KH	LJ		W	T	Weight (kg)
55±1	22	110	M6×20	36	18 ⁰ -0.2	0.5±0.75		8	7	7 (8)

3.6.2 MS1H3-85B15CD-A33*Z

3.6.2.1

Motor Model		Torque-Speed characteristics	
Flange Size (mm)	130		
Inertia, Capacity	Medium inertia, medium capacity		
Rated output (kW)	0.85		
Voltage (V)	380		
Rated torque (N·m)	5.39		
Maximum torque (N·m)	13.5	Heatsink-based derating curve	
Rated Current (Arms)	3.3		
Maximum Current (Arms)	8.25		
Rated speed (RPM)	1500		
Maximum speed (RPM)	3000		
Torque coefficient (N·m/Arms)	1.87		
Rotor moment of inertia (kg·cm ²)	Motor without brake	13.3	
	Motor with brake	14	

Electrical specifications of the motor with brake

Holding torque (N·m)	Supply Voltage (V DC)±10%	Rated Power (W)	Coil Resistance (Ω) (±7%)	Exciting Current (A)	Apply Time (ms)	Release Time (ms)	Backlash (°)
12	24	19.4	29.7	0.81	≤ 120	≤ 60	≤ 0.5

Allowable load

LF (mm)	Allowable Radial Load (N)	Allowed Axial Load (N)
45	686	196

Product dimensions (unit: mm)

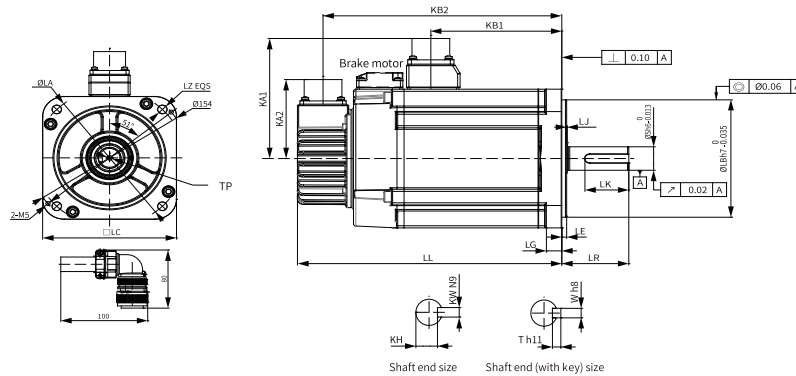

LL	LC	LE	LA	LZ	KA1	KB1	KA2	KB2	LG	kW
146 (182)	130	4	145	4-Ø9	103	72.5	74	125 (161)	14	8
LR	S	LB	TP	LK	KH	LJ		W	T	Weight (kg)
55±1	22	110	M6×20	36	18° -0.2	0.5±0.75		8	7	7 (8)

3.6.3 MS1H3-13C15CB-A33*Z

3.6.3.1

Motor Model		Torque-Speed characteristics	
Flange Size (mm)	130		
Inertia, Capacity	Medium inertia, medium capacity		
Rated output (kW)	1.3		
Voltage (V)	220		
Rated torque (N·m)	8.34		
Maximum torque (N·m)	20.85		
Rated Current (Arms)	10	Heatsink-based derating curve	
Maximum Current (Arms)	25		
Rated speed (RPM)	1500		
Maximum speed (RPM)	3000		
Torque coefficient (N·m/Arms)	0.95		
Rotor moment of inertia (kg·cm ²)	Motor without brake		
	Motor with brake	18.5	

Electrical specifications of the motor with brake

Holding torque (N·m)	Supply Voltage (V DC)±10%	Rated Power (W)	Coil Resistance (Ω) (±7%)	Exciting Current (A)	Apply Time (ms)	Release Time (ms)	Backlash (°)
12	24	19.4	29.7	0.81	≤ 120	≤ 60	≤ 0.5

Allowable load

LF (mm)	Allowable Radial Load (N)	Allowed Axial Load (N)
45	686	196

Product dimensions (unit: mm)

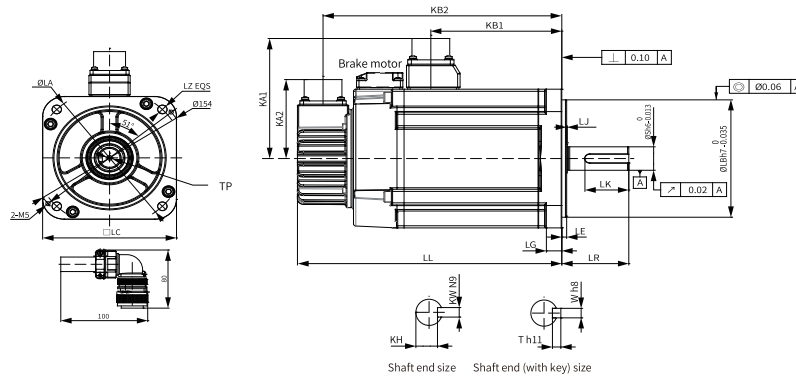

LL	LC	LE	LA	LZ	KA1	KB1	KA2	KB2	LG	kW
163 (199)	130	4	145	4-Ø9	103	89.5	74	142 (178)	14	8
LR	S	LB	TP	LK	KH	LJ		W	T	Weight (kg)
55±1	22	110	M6×20	36	18 ⁰ -0.2	0.5±0.75		8	7	8 (9.5)

3.6.4 MS1H3-13C15CD-A33*Z

3.6.4.1

Motor Model		Torque-Speed characteristics	
Flange Size (mm)	130		
Inertia, Capacity	Medium inertia, medium capacity		
Rated output (kW)	13		
Voltage (V)	380		
Rated torque (N·m)	8.34		
Maximum torque (N·m)	20.85		
Rated Current (Arms)	5		
Maximum Current (Arms)	12.5		
Rated speed (RPM)	1500		
Maximum speed (RPM)	3000		
Torque coefficient (N·m/Arms)	1.87		
Rotor moment of inertia (kg·cm ²)	Motor without brake		
	Motor with brake	18.5	

Electrical specifications of the motor with brake

Holding torque (N·m)	Supply Voltage (V DC)±10%	Rated Power (W)	Coil Resistance (Ω) (±7%)	Exciting Current (A)	Apply Time (ms)	Release Time (ms)	Backlash (°)
12	24	19.4	29.7	0.81	≤ 120	≤ 60	≤ 0.5

Allowable load

LF (mm)	Allowable Radial Load (N)	Allowed Axial Load (N)
45	686	196

Product dimensions (unit: mm)

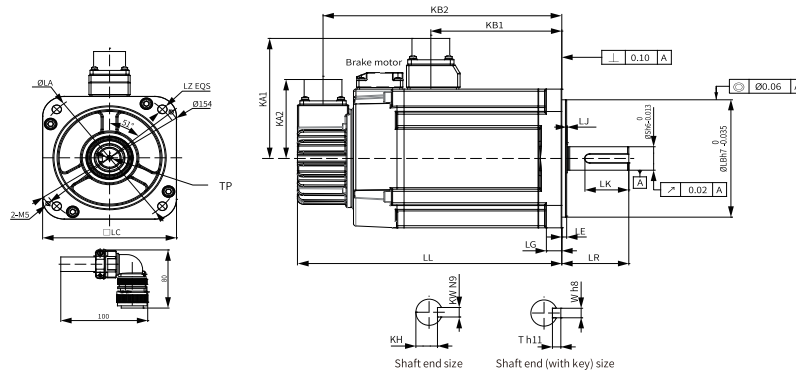

LL	LC	LE	LA	LZ	KA1	KB1	KA2	KB2	LG	kW
163 (199)	130	4	145	4-Ø9	103	89.5	74	142 (178)	14	8
LR	S	LB	TP	LK	KH	LJ		W	T	Weight (kg)
55±1	22	110	M6×20	36	18 ⁰ -0.2	0.5±0.75		8	7	8 (9.5)

3.6.5 MS1H3-18C15CD-A33*Z

3.6.5.1

Motor Model		Torque-Speed characteristics		
Flange Size (mm)	130	<p>— A Continuous working area — B Short term working area</p>		
Inertia, Capacity	Medium inertia, medium capacity			
Rated output (kW)	1.8			
Voltage (V)	380			
Rated torque (N·m)	11.5			
Maximum torque (N·m)	28.75			
Rated Current (Arms)	6.6			
Maximum Current (Arms)	16.5			
Rated speed (RPM)	1500			
Maximum speed (RPM)	3000			
Torque coefficient (N·m/Arms)	1.87	<p>Rating reduction (%) vs Heatsink size (mm)</p>		
Rotor moment of inertia (kg·cm ²)	Motor without brake			25
	Motor with brake			25.7

Electrical specifications of the motor with brake

Holding torque (N·m)	Supply Voltage (V DC)±10%	Rated Power (W)	Coil Resistance (Ω) (±7%)	Exciting Current (A)	Apply Time (ms)	Release Time (ms)	Backlash (°)
12	24	19.4	29.7	0.81	≤ 120	≤ 60	≤ 0.5

Allowable load

LF (mm)	Allowable Radial Load (N)	Allowed Axial Load (N)
45	686	196

Product dimensions (unit: mm)

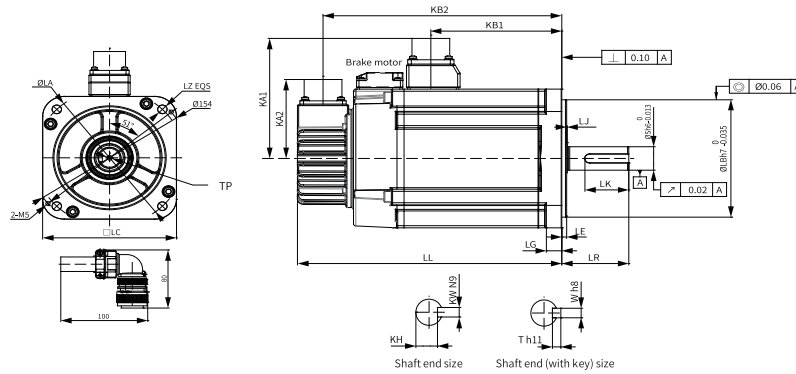

LL	LC	LE	LA	LZ	KA1	KB1	KA2	KB2	LG	kW
181 (217)	130	4	145	4-Ø9	103	107.5	74	160 (196)	14	8
LR	S	LB	TP	LK	KH	LJ		W	T	Weight (kg)
55±1	22	110	M6×20	36	18 ⁰ -0.2	0.5±0.75		8	7	9 (11)

3.6.6 MS1H3-29C15CD-A33*Z

3.6.6.1

Motor Model		Torque-Speed characteristics		
Flange Size (mm)	180			
Inertia, Capacity	Medium inertia, medium capacity			
Rated output (kW)	2.9			
Voltage (V)	380			
Rated torque (N·m)	18.6			
Maximum torque (N·m)	46.5			
Rated Current (Arms)	11.9			
Maximum Current (Arms)	29.75			
Rated speed (RPM)	1500			
Maximum speed (RPM)	3000			
Torque coefficient (N·m/Arms)	1.82			
Rotor moment of inertia (kg·cm ²)	Motor without brake			55
	Motor with brake			57.2

Electrical specifications of the motor with brake

Holding torque (N·m)	Supply Voltage (V DC) ±10%	Rated Power (W)	Coil Resistance (Ω) (±7%)	Exciting Current (A)	Apply Time (ms)	Release Time (ms)	Backlash (°)
50	24	40	14.4	1.67	≤ 200	≤ 100	≤ 0.5

Allowable load

LF (mm)	Allowable Radial Load (N)	Allowed Axial Load (N)
79	1470	490

Product dimensions (unit: mm)

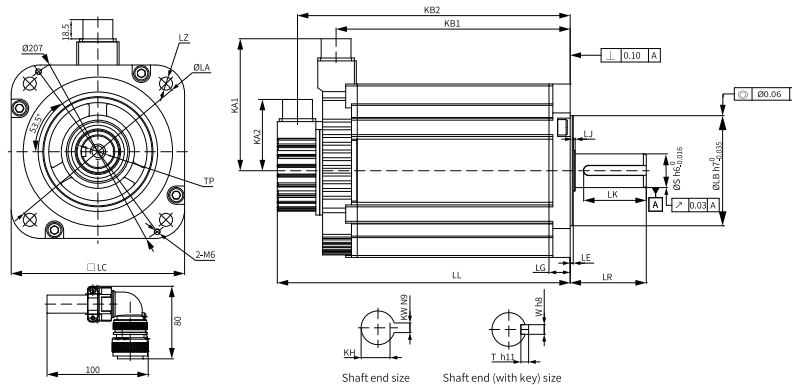

LL	LC	LE	LA	LZ	KA1	KA2	KW	LG	KB1	KB2
197 (273)	180	3.2±0.3	200	4-Ø13.5	138	74	10	18	136 (134)	177 (253)
LR	S	LB	TP	LK	KH	LJ		W	T	Weight (kg)
79±1	35	114.3	M12×25	65	30 ⁰ -0.2	0.3±0.75		10	8	15 (25)

3.6.7 MS1H3-44C15CD-A33*Z

3.6.7.1

Motor Model		Torque-Speed characteristics		
Flange Size (mm)	180			
Inertia, Capacity	Medium inertia, medium capacity			
Rated output (kW)	4.4			
Voltage (V)	380			
Rated torque (N·m)	28.4			
Maximum torque (N·m)	71.1			
Rated Current (Arms)	16.5	Heatsink-based derating curve		
Maximum Current (Arms)	40.5			
Rated speed (RPM)	1500			
Maximum speed (RPM)	3000			
Torque coefficient (N·m/Arms)	1.9			
Rotor moment of inertia (kg·cm ²)	Motor without brake			88.9
	Motor with brake			90.8

Electrical specifications of the motor with brake

Holding torque (N·m)	Supply Voltage (V DC)±10%	Rated Power (W)	Coil Resistance (Ω) (±7%)	Exciting Current (A)	Apply Time (ms)	Release Time (ms)	Backlash (°)
50	24	40	14.4	1.67	≤ 200	≤ 100	≤ 0.5

Allowable load

LF (mm)	Allowable Radial Load (N)	Allowed Axial Load (N)
79	1470	490

Product dimensions (unit: mm)

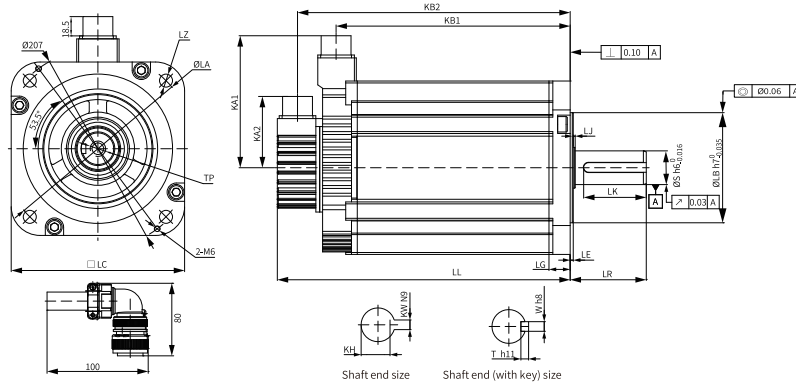

LL	LC	LE	LA	LZ	KA1	KA2	KW	LG	KB1	KB2
230 (307)	180	3.2±0.3	200	4-Ø13.5	138	74	10	18	169 (167)	210 (286)
LR	S	LB	TP	LK	KH	LJ		W	T	Weight (kg)
79±1	35	114.3	M12×25	65	30 ⁰ -0.2	0.3±0.75		10	8	19.5 (30)

3.6.8 MS1H3-55C15CD-A33*Z

3.6.8.1

Motor Model		Torque-Speed characteristics	
Flange Size (mm)	180		
Inertia, Capacity	Medium inertia, medium capacity		
Rated output (kW)	5.5		
Voltage (V)	380		
Rated torque (N·m)	35		
Maximum torque (N·m)	87.6		
Heatsink-based derating curve		Heatsink-based derating curve	
Rated Current (Arms)	20.85		
Maximum Current (Arms)	52		
Rated speed (RPM)	1500		
Maximum speed (RPM)	3000		
Torque coefficient (N·m/Arms)	1.74		
Rotor moment of inertia (kg·cm ²)	Motor without brake		
	Motor with brake	109.5	

Electrical specifications of the motor with brake

Holding torque (N·m)	Supply Voltage (V DC)±10%	Rated Power (W)	Coil Resistance (Ω) (±7%)	Exciting Current (A)	Apply Time (ms)	Release Time (ms)	Backlash (°)
50	24	40	14.4	1.67	≤ 200	≤ 100	≤ 0.5

Allowable load

LF (mm)	Allowable Radial Load (N)	Allowed Axial Load (N)
113	1764	588

Product dimensions (unit: mm)

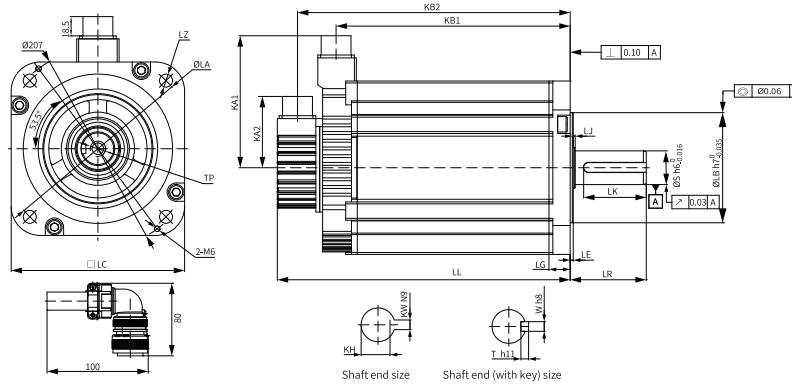

LL	LC	LE	LA	LZ	KA1	KA2	KW	LG	KB1	KB2
274 (350)	180	3.2±0.3	200	4-Ø13.5	138	74	12	18	213 (211)	254 (330)
LR	S	LB	TP	LK	KH	LJ		W	T	Weight (kg)
113±1	42	114.3	M16×32	96	37 ⁰ -0.2	0.3±0.75		12	8	28 (38)

3.6.9 MS1H3-75C15CD-A33*Z

3.6.9.1

Motor Model		Torque-Speed characteristics		
Flange Size (mm)	180			
Inertia, Capacity	Medium inertia, medium capacity			
Rated output (kW)	7.5			
Voltage (V)	380			
Rated torque (N·m)	48			
Maximum torque (N·m)	119			
Rated Current (Arms)	25.7	Heatsink-based derating curve		
Maximum Current (Arms)	65			
Rated speed (RPM)	1500			
Maximum speed (RPM)	3000			
Torque coefficient (N·m/Arms)	1.99			
Rotor moment of inertia (kg·cm ²)	Motor without brake			141
	Motor with brake			143.1

Electrical specifications of the motor with brake

Holding torque (N·m)	Supply Voltage (V DC)±10%	Rated Power (W)	Coil Resistance (Ω) (±7%)	Exciting Current (A)	Apply Time (ms)	Release Time (ms)	Backlash (°)
50	24	40	14.4	1.67	≤ 200	≤ 100	≤ 0.5

Allowable load

LF (mm)	Allowable Radial Load (N)	Allowed Axial Load (N)
113	1764	588

Product dimensions (unit: mm)

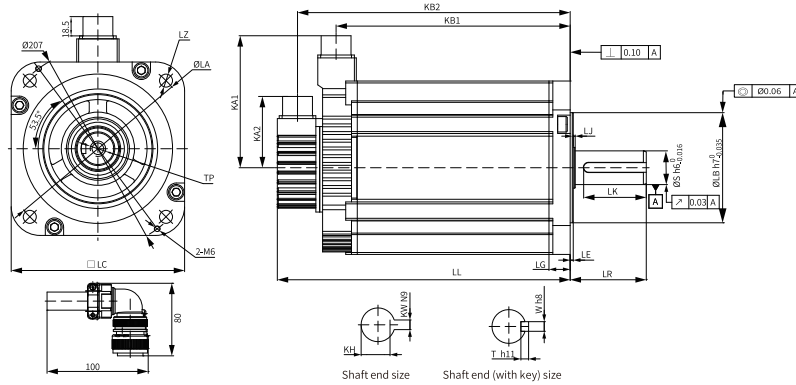

LL	LC	LE	LA	LZ	KA1	KA2	KW	LG	KB1	KB2
330 (407)	180	3.2±0.3	200	4-Ø13.5	138	74	12	18	269 (267)	310 (386)
LR	S	LB	TP	LK	KH	LJ		W	T	Weight (kg)
113±1	42	114.3	M16×32	96	37 ⁰ -0.2	0.3±0.75		12	8	32 (42)

3.7 Motor with Medium Inertia and Small Capacity (MS1H4)

3.7.1 MS1H4-10B30CB-A33*Z

3.7.1.1

Motor Model		Torque-Speed characteristics		
Flange Size (mm)	40			
Inertia, Capacity	Low inertia, small capacity			
Rated output (kW)	0.1			
Voltage (V)	220			
Rated torque (N·m)	0.32			
Maximum torque (N·m)	1.12			
Rated Current (Arms)	1.3			
Maximum Current (Arms)	4.70			
Rated speed (RPM)	3000			
Maximum speed (RPM)	6000			
Torque coefficient (N·m/Arms)	0.26	Heatsink-based derating curve 		
Rotor moment of inertia (kg·cm ²)	Motor without brake			0.102
	Motor with brake			0.104

Electrical specifications of the motor with brake

Holding torque (N·m)	Supply Voltage (V DC) ±10%	Rated Power (W)	Coil Resistance (Ω) (±7%)	Exciting Current (A)	Apply Time (ms)	Release Time (ms)	Backlash (°)
0.32	24	6.1	94.4	0.25	≤ 40	≤ 20	≤ 1.5

Allowable load

LF (mm)	Allowable Radial Load (N)	Allowed Axial Load (N)
20	78	54

Product dimensions (unit: mm)

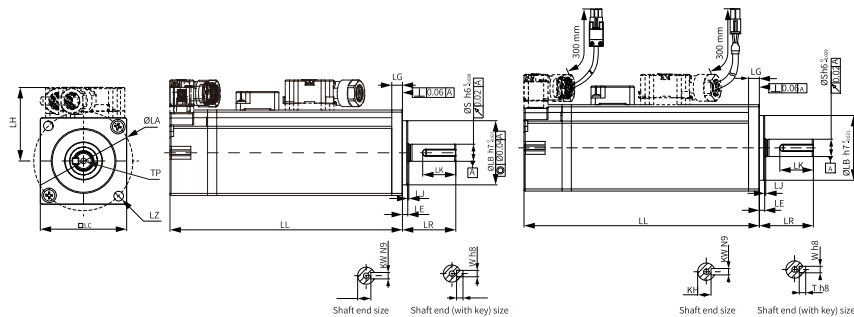

LL	LC	LR	LA	LZ	LH	LG	LE	LJ
89.9 (120.5)	40	25 ± 0.5	46	2-Ø4.5	34	5	2.5 ± 0.5	0.5 ± 0.35
S	LB	TP	LK	KH	kW	W	T	Weight (kg)
8	30	M3x6	15.5	6.2 ⁰ -0.1	3	3	3	0.45 (0.64)

3.7.2 MS1H4-40B30CB-A33*Z(-S)

3.7.2.1

Motor Model		Torque-Speed characteristics	
Flange Size (mm)	60		
Inertia, Capacity	Medium inertia, low capacity		
Rated output (kW)	0.4		
Voltage (V)	220		
Rated torque (N·m)	1.27		
Maximum torque (N·m)	4.46		
Rated Current (Arms)	2.8		
Maximum Current (Arms)	10.1		
Rated speed (RPM)	3000		
Maximum speed (RPM)	6000		
Torque coefficient (N·m/Arms)	0.53		
Rotor moment of inertia (kg·cm ²)	Motor without brake		
	Motor with brake	0.667	

Electrical specifications of the motor with brake

Holding torque (N·m)	Supply Voltage (V DC) ±10%	Rated Power (W)	Coil Resistance (Ω) (±7%)	Exciting Current (A)	Apply Time (ms)	Release Time (ms)	Backlash (°)
1.5	24	7.6	75.79	0.32	≤ 60	≤ 20	≤ 1.5

Allowable load

LF (mm)	Allowable Radial Load (N)	Allowed Axial Load (N)
25	245	74

Product dimensions (unit: mm)

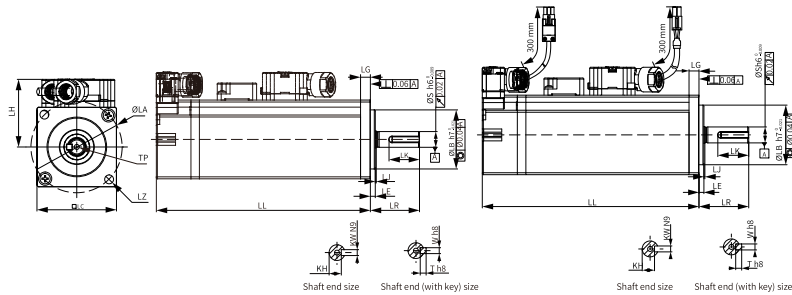

LL	LC	LR	LA	LZ	LH	LG	LE	LJ
105 (128)	60	30 ± 0.5	70	4-Ø5.5	44	7.5	3 ± 0.5	0.5 ± 0.35
S	LB	TP	LK	KH	kW	W	T	Weight (kg)
14	50	M5x8	16.5	11 ⁰ -0.1	5	5	5	1.27 (1.62)

3.7.3 MS1H4-75B30CB-A33*Z(-S)

3.7.3.1

Motor Model		Torque-Speed characteristics		
Flange Size (mm)	80	<p>Speed (rpm) vs Torque (N·m) graph showing continuous (A) and short-term (B) working areas.</p>		
Inertia, Capacity	Medium inertia, low capacity			
Rated output (kW)	0.75			
Voltage (V)	220			
Rated torque (N·m)	2.39			
Maximum torque (N·m)	8.36			
Rated Current (Arms)	4.8	Heatsink-based derating curve		
Maximum Current (Arms)	16.9	<p>Rating reduction (%) vs Heatsink size (mm) graph.</p>		
Rated speed (RPM)	3000			
Maximum speed (RPM)	6000			
Torque coefficient (N·m/Arms)	0.58			
Rotor moment of inertia (kg·cm ²)	Motor without brake			2
	Motor with brake			2.012

Electrical specifications of the motor with brake

Holding torque (N·m)	Supply Voltage (V DC) ±10%	Rated Power (W)	Coil Resistance (Ω) (±7%)	Exciting Current (A)	Apply Time (ms)	Release Time (ms)	Backlash (°)
3.2	24	10	57.6	0.42	≤ 60	≤ 40	≤ 1.0

Allowable load

LF (mm)	Allowable Radial Load (N)	Allowed Axial Load (N)
35	392	147

Product dimensions (unit: mm)

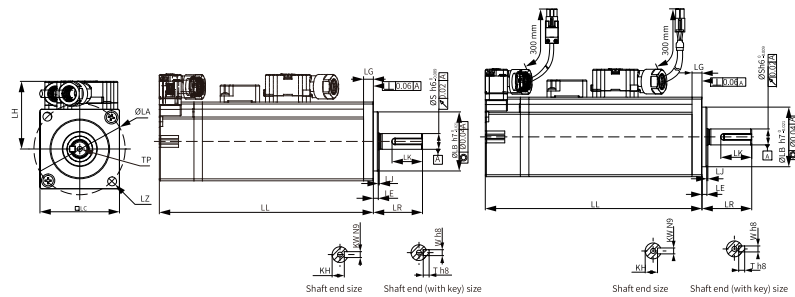

LL	LC	LR	LA	LZ	LH	LG	LE	LJ
117.5 (147.5)	80	35±0.5	90	4-Ø7	54	7.7	3±0.5	0.5±0.35
S	LB	TP	LK	KH	kW	W	T	Weight (kg)
19	70	M6×20	25	15 ⁰ -0.1	6	6	6	2.40 (3.04)

4 Optional parts

4.1 List of Optional Parts

Type	Name	Location	Applicable Model	Description
Peripheral components	Fuse and circuit breaker	Input side of the servo drive	All	To comply with EN 61800-5-1 and UL61800-5-1 standards, install a fuse/circuit breaker on the input side of the servo drive to prevent accidents caused by short circuit in the internal circuit.
	AC Input Reactor	Input side of the servo drive		Eliminates harmonics on the input side and improves the power factor on the input side.
	EMC filter	Input side of the servo drive		Reduces the conducted and radiated interference escaped from the servo drive to the outside.
	Magnetic ring	Output side of the servo drive		Reduces interferences to the outside and the bearing current.
		Signal cable		Improves the anti-interference performance of signals.

4.2 Cables

4.2.1 Description of the Model Number

Power cable

$$\frac{S6-L-M}{\textcircled{1}} \frac{000}{\textcircled{2}\textcircled{3}\textcircled{4}} - \frac{3.0}{\textcircled{5}} - \frac{T}{\textcircled{6}} - \frac{X}{\textcircled{7}}$$

<p>① Cable Type</p> <p>S6-L-B/M: motion control power cable</p> <p>B: with brake</p> <p>M: without brake</p>	<p>④ Connector type at motor side</p> <p>0: 6-core plastic connector</p> <p>1: 9-core military-spec connector</p> <p>2: 6-core military-spec connector</p> <p>4: Middle series 4-core connector</p> <p>5: Middle series 6-core connector</p> <p>6: SM-PW series 6-core connector</p> <p>7: SDC-06T series connector (front outgoing)</p> <p>8: SDC-06T series connector (rear outgoing)</p>	<p>⑤ Cable Length (m)</p> <p>3.0: 3 m</p> <p>5.0: 5 m</p> <p>8.0: 8 m</p> <p>10.0: 10 m</p>
<p>② Connector type at drive side</p> <p>0: U-shaped cable lug</p> <p>1: Needle-shaped cable lug</p>		<p>⑥ Special requirements</p> <p>T: Drag chain</p> <p>TS: Shielded flexible cable</p> <p>S: Single shield</p> <p>TTS: Drag chain shielding 20 million times</p>
<p>③ Cable Size (mm²)</p> <p>0: Wire-saving encoder</p> <p>1: 100/130/180 flange (drive rated current < 13 A)</p> <p>2: 180 (drive rated current > 13 A)</p> <p>3: 4×12 AWG</p> <p>4: 4×14 AWG</p> <p>5: 4×16 AWG</p> <p>6: 4×18 AWG</p> <p>7: 4×20 AWG</p>		<p>⑦ Manufacturer</p> <p>YGS: Igus</p>

Model number of encoder cables

S6-L-P 0 0 0 - 3.0 - T - X
① ② ③ ④ ⑤ ⑥ ⑦

<p>① Cable Type</p> <p>S6-L-P: Motion control encoder cable</p>	<p>④ Connector type at motor side</p> <p>0: 9-core plastic connector 1: 9-core military-spec connector 2: 6-core military-spec connector 4: Middle series 4-core connector 5: Middle series 6-core connector 6: SM-PW series 6-core connector 7: SDC-07T series connector (front outgoing) 8: SDC-07T series connector (rear outgoing) 9: DB9 2-rows-Inno A: DB15 2-row-RSF B: DB15 2-row-Renishaw C: DB15 2-row-Banyan D: DB15 3-row-Inovance</p>	<p>⑤ Cable Length (m)</p> <p>3.0: 3 m 5.0: 5 m 8.0: 8 m 10.0: 10 m</p>
<p>② Connector type at drive side</p> <p>0: DB9 1: USB 2: DB15</p>		<p>⑥ Special requirements</p> <p>T: Drag chain TS: Shielded flexible cable TTS: Drag chain shielding 20 million times</p>
<p>③ Encode</p> <p>0: Wire-saving encoder 1: Communication incremental encoder 2: Communication multi-turn absolute encoder 3: Optical 4: Magnetic</p>		<p>⑦ Manufacturer</p> <p>YGS: Igus</p>

Model number of communication cables

S6N-L-T 00 - 3.0
① ② ③

<p>① Cable Type</p> <p>S6-L-T: Motion control communication cable S6N-L-T: IS620F Motion Control Encoder Cable (only for servo drive PC communication cable)</p>	<p>② Cable type</p> <p>00: Servo drive PC communication cable 01: Servo drive network communication cable (CAN&485) 02: Servo drive and PLC communication cable 03: Servo drive termination resistor cable 04: Servo drive network communication cable (EtherCAT) 05: Servo drive network communication cable (Mechatrolink II) 06: Servo drive termination resistor cable (Mechatrolink II)</p>	<p>③ Cable Length (m)</p> <p>3.0: 3 m 5.0: 5 m 8.0: 8 m 10.0: 10 m</p>
--	---	--

4.2.2 Cable Type

Fixed cables

Do not bend or move fixed cables during use. Bending or moving fixed cables may damage the cables and lead to a series of cable-related faults such as poor contact. Secure fixed cables through fixed binding. Certain bending radius must be available for the cables to prevent stress.

Flexible cables

Flexible cables can move along with cable carriers without a high risk of abrasion.

Note

- Do not twist cables inside the cable carrier.
 - Ensure the cable can move within the bending radius. Do not move the cables by force. Ensure a relative movement between cables or between the cable and the guiding device is available.
 - Do not fix or bundle the cables inside the cable carrier. The cables can be bundled and fixed only at two unmovable ends of the cable carrier.
-

Oil-resistant cables.

Oil-resistant cables apply to applications requiring shielded power cables, such as machine tools, cutting fluids, and cutting compounds.

Note

- S6-C24 cable kit is required for terminal-type motor encoder cables longer than 25 m. Contact Inovance sales staff for details on the cable length.
 - Contact Inovance sales staff for flying leads type motor encoder cables longer than 25 m..
-

4.2.3 Cable Selection

Power cable

Motor Model	Cable Name	Cable Model	L Cable Length (mm)	Tolerance (T) (mm)	Outline Drawing	
MS1H1/ MS1H4 terminal- type motor	Front outlet	Power cable for motor without brake	S6-L-M107-3.0	3000	(-30.30)	
		S6-L-M107-5.0	5000	(-30.50)		
		S6-L-M107-10.0	10000	(-30.80)		
		Brake	S6-L-B107-3.0	3000	(-30.30)	
			S6-L-B107-5.0	5000	(-30.50)	
			S6-L-B107-10.0	10000	(-30.80)	
	Rear outlet	Power cable for motor without brake	S6-L-M108-3.0	3000	(-30.30)	
		S6-L-M108-5.0	5000	(-30.50)		
		S6-L-M108-10.0	10000	(-30.80)		
		Brake	S6-L-B108-3.0	3000	(-30.30)	
			S6-L-B108-5.0	5000	(-30.50)	
			S6-L-B108-10.0	10000	(-30.80)	
MS1H1/ MS1H4 lead- type (-S) motor	Power cable for motor without brake	S6-L-M100-3.0	3000	(-30.30)		
		S6-L-M100-5.0	5000	(-30.50)		
		S6-L-M100-10.0	10000	(-30.80)		
	Brake	S6-L-B100-3.0	3000	(-30.30)		
		S6-L-B100-5.0	5000	(-30.50)		
		S6-L-B100-10.0	10000	(-30.80)		
MS1H2 motor rated 3 kW or below/ MS1H3 motor rated 1.8 kW or below	Power cable for motor without brake	S6-L-M111-3.0	3000	(-30.30)		
		S6-L-M111-5.0	5000	(-30.50)		
		S6-L-M111-10.0	10000	(-30.80)		
	Brake	S6-L-B111-3.0	3000	(-30.30)		
		S6-L-B111-5.0	5000	(-30.50)		
		S6-L-B111-10.0	10000	(-30.80)		

Motor Model	Cable Name	Cable Model	L Cable Length (mm)	Tolerance (T) (mm)	Outline Drawing
MS1H2 motor rated 4 kW/5 kW	Power cable for motor without brake	S6-L-M011-3.0	3000	(-30.30)	
		S6-L-M011-5.0	5000	(-30.50)	
		S6-L-M011-10.0	10000	(-30.80)	
	Brake	S6-L-B011-3.0	3000	(-30.30)	
		S6-L-B011-5.0	5000	(-30.50)	
		S6-L-B011-10.0	10000	(-30.80)	
MS1H3 motor rated 2.9 kW	Power cable for motor without brake	S6-L-M112-3.0	3000	(-30.30)	
		S6-L-M112-5.0	5000	(-30.50)	
		S6-L-M112-10.0	10000	(-30.80)	
	Brake	S6-L-B112-3.0	3000	(-30.30)	
		S6-L-B112-5.0	5000	(-30.50)	
		S6-L-B112-10.0	10000	(-30.80)	
MS1H3 motor rated 4.4 kW or above	Power cable for motor without brake	S6-L-M022-3.0	3000	(-30.30)	
		S6-L-M022-5.0	5000	(-30.50)	
		S6-L-M022-10.0	10000	(-30.80)	
	Brake	S6-L-B022-3.0	3000	(-30.30)	
		S6-L-B022-5.0	5000	(-30.50)	
		S6-L-B022-10.0	10000	(-30.80)	

Encoder cable

Motor Model	Cable Name	Cable Model	L Cable Length (mm)	Tolerance (T) (mm)	Outline Drawing	
MS1H1/MS1H4 terminal-type motor	Front outlet	Single-turn absolute encoder cable	S6-L-P114-3.0	3000	(-30.30)	
			S6-L-P114-5.0	5000	(-30.50)	
			S6-L-P114-10.0	10000	(-30.80)	
		Multi-turn absolute encoder cable	S6-L-P124-3.0	3000	(-30.30)	
			S6-L-P124-5.0	5000	(-30.50)	
			S6-L-P124-10.0	10000	(-30.80)	
	Rear outlet	Single-turn absolute encoder cable	S6-L-P115-3.0	3000	(-30.30)	
			S6-L-P115-5.0	5000	(-30.50)	
			S6-L-P115-10.0	10000	(-30.80)	
		Multi-turn absolute encoder cable	S6-L-P125-3.0	3000	(-30.30)	
			S6-L-P125-5.0	5000	(-30.50)	
			S6-L-P125-10.0	10000	(-30.80)	
MS1H1/MS1H4 lead-type (-S) motor	Single-turn absolute encoder cable	S6-L-P110-3.0	3000	(-30.30)		
		S6-L-P110-5.0	5000	(-30.50)		
		S6-L-P110-10.0	10000	(-30.80)		
	Multi-turn absolute encoder cable	S6-L-P120-3.0	3000	(-30.30)		
		S6-L-P120-5.0	5000	(-30.50)		
		S6-L-P120-10.0	10000	(-30.80)		
MS1H2/MS1H3 motor	Single-turn absolute encoder cable	S6-L-P111-3.0	3000	(-30.30)		
		S6-L-P111-5.0	5000	(-30.50)		
		S6-L-P111-10.0	10000	(-30.80)		
	Multi-turn absolute encoder cable	S6-L-P121-3.0	3000	(-30.30)		
		S6-L-P121-5.0	5000	(-30.50)		
		S6-L-P121-10.0	10000	(-30.80)		

Communication cables

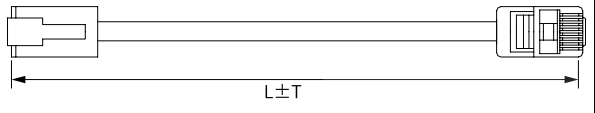
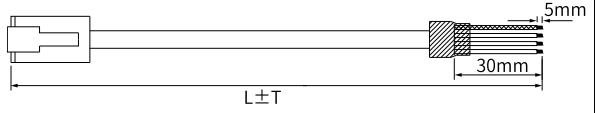
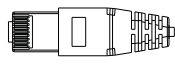
Cable Name	Cable Model	Cable Length (mm)	Tolerance (T) (mm)	Outline Drawing
Servo drive network communication cable	S6-L-T04-0.3	300	(-10.10)	
Servo drive to host controller communication cable	S6-L-T02-2.0	2000	(-20.20)	
Servo Drive Termination Resistor Connector	S6-L-T03-0.0	-	-	

Connector Kit

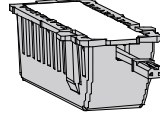
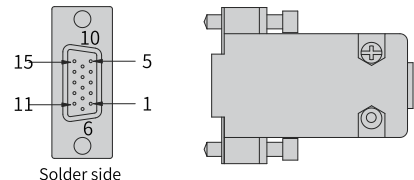
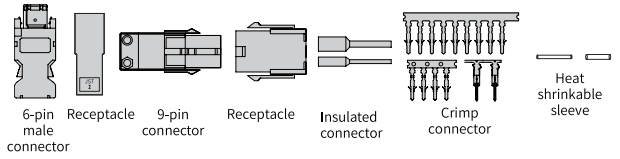
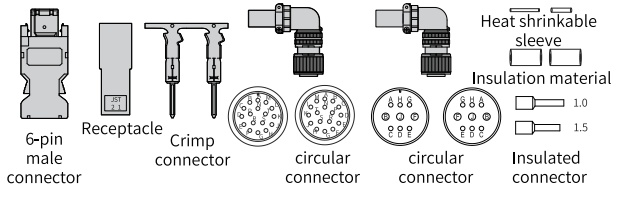
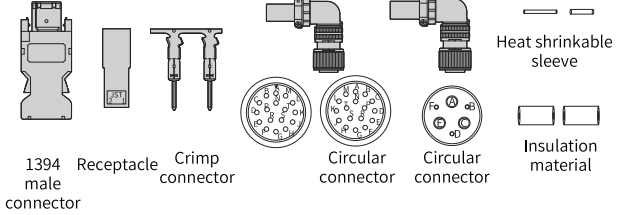
Name	Model	Outline Drawing
Battery kit	S6-C4A	
CN7 terminal (DB15)	S6-C6	
MS1H1 lead-type (-S) motor connector	S6-C26	
MS1H2/MS1H3 motor connector (1.8 kW and below)	S6-C29	
MS1H3 motor connector (2.9 kW and above)	S6-C39	

4.3 Peripheral components

4.3.1 Fuse

To prevent accidents caused by short circuit, install a fuse on the input side of the servo drive.

Table 4-1 List of recommended fuses

Servo drive SV670N****I			Recommended Fuse		
Size	Model	Rated Input Current (A)	Manufacturer	Rated Current (A)	Model
Single-phase 220 V					
Size A	S1R6	2.3	Bussmann	15	FWP-15B
	S2R8	4.0		20	FWP-20B
Size C	S5R5	7.9		35	FWP-35C
	S7R6	9.6		40	FWP-40C
Size D	S012	12.8		40	FWP-40C
Three-phase 220 V					
Size A	S1R6	1.1	Bussmann	15	FWP-15B
	S2R8	1.8		20	FWP-20B
Size C	S5R5	4.4		35	FWP-35C
	S7R6	5.1		40	FWP-40C
Size D	S012	8.0		35	FWP-35C
Size E	S018	8.7		50	FWP-50C
	S022	11.0		70	FWP-70C
	S027	23.8		90	FWP-90C
Three-phase 380 V					
Size C	T3R5	2.4	Bussmann	15	FWP-15B
	T5R4	3.6		20	FWP-20B
Size D	T8R4	5.6		20	FWP-20B
	T012	8.0		35	FWP-35C
Size E	T017	12.0		50	FWP-50C
	T021	16.0		70	FWP-70C
	T026	21.0		90	FWP-90C

4.3.2 Electromagnetic contactor

Table 4-2 Recommended electromagnetic contactor models

Servo drive SV670N****I			Recommended Contactor		
Size	Model	Rated Input Current (A)	Manufacturer	Current (A)	Model
Single-phase 220 V					
Size A	S1R6	2.3	Schneider	9	LC1 D09
	S2R8	4.0		9	LC1 D09
Size C	S5R5	7.9		9	LC1 D09
	S7R6	9.6		12	LC1 D12
Size D	S012	12.8		18	LC1 D18
Three-phase 220 V					

Servo drive SV670N****I			Recommended Contactor		
Size	Model	Rated Input Current (A)	Manufacturer	Current (A)	Model
Size A	S1R6	1.1	Schneider	9	LC1 D09
	S2R8	1.8			
Size C	S5R5	4.4			
	S7R6	5.1			
Size D	S012	8.0		9	LC1 D09
Size E	S018	8.7		12	LC1 D12
	S022	11.0		25	LC1 D25
	S027	23.8			
Three-phase 380 V					
Size C	T3R5	2.4	Schneider	9	LC1 D09
	T5R4	3.6		9	LC1 D09
Size D	T8R4	5.6		9	LC1 D09
	T012	8.0		9	LC1 D09
Size E	T017	12.0		18	LC1 D18
	T021	16.0		18	LC1 D18
	T026	21.0		25	LC1 D25

4.3.3 Circuit breaker

Table 4-3 Recommended circuit breaker models

Servo drive SV670N****I			Recommended Circuit Breaker		
Size	Model	Rated Input Current (A)	Manufacturer	Current (A)	Model
Single-phase 220 V					
Size A	S1R6	2.3	Schneider	4	OSMC32N2C4
	S2R8	4.0		6	OSMC32N2C6
Size C	S5R5	7.9		16	OSMC32N2C16
	S7R6	9.6		16	OSMC32N2C16
Size D	S012	12.8		20	OSMC32N2C20
Three-phase 220 V					
Size A	S1R6	1.1	Schneider	4	OSMC32N3C4
	S2R8	1.8		6	OSMC32N3C6
Size C	S5R5	4.4		16	OSMC32N3C16
	S7R6	5.1		16	OSMC32N3C16
Size D	S012	8.0		16	OSMC32N3C16
Size E	S018	8.7		20	OSMC32N3C20
	S022	11.0		25	OSMC32N3C25
	S027	23.8		32	OSMC32N3C32
Three-phase 380 V					
Size C	T3R5	2.4	Schneider	4	OSMC32N2C4
	T5R4	3.6		6	OSMC32N2C6
Size D	T8R4	5.6		10	OSMC32N2C10
	T012	8.0		16	OSMC32N2C16
Size E	T017	12.0		20	OSMC32N2C20
	T021	16.0		25	OSMC32N2C25
	T026	21.0		32	OSMC32N2C32

Note

For UL-compliant products, see section "UL/cUL Certification" in SV670N Series Servo Drive Hardware Guide for recommended fuse/circuit breaker models.

If a residual current device (RCD) is needed, select the RCD according to the following requirements:

- Use a B-type RCD because the drive may generate DC leakage current in the protective conductor.
- For each drive, use an RCD whose tripping current is not lower than 100 mA to prevent RCD malfunction due to high-frequency leakage current generated by the drive.
- When multiple drives are connected in parallel and share one RCD, select an RCD whose tripping current is not lower than 300 mA.
- Use Chint or Schneider RCDs (recommended).

4.3.4 AC Input Reactor

Model selection

An AC input reactor is optional and mainly used to reduce harmonics in the input current. Install an external reactor as needed in actual applications. The following table lists the recommended manufacturers and models of input reactors.

Table 4-4 AC input reactor model selection

Servo drive SV670N****I			Applicable Reactor	Inductance (mH)
Size	Model	Rated Input Current (A)		
Three-phase 220 V				
Size A	S1R6	1.1	MD-ACL-10-5-4T	5
	S2R8	1.8	MD-ACL-10-5-4T	5
Size C	S5R5	4.4	MD-ACL-10-5-4T	5
	S7R6	5.1	MD-ACL-10-5-4T	5
Size D	S012	8.0	MD-ACL-10-5-4T	5
Size E	S018	8.7	MD-ACL-15-3-4T	3
	S022	11.0	MD-ACL-15-3-4T	3
	S027	23.8	MD-ACL-40-1.45-4T	1.45
Three-phase 380 V				
Size C	T3R5	2.4	MD-ACL-10-5-4T	5
	T5R4	3.6	MD-ACL-10-5-4T	5
Size D	T8R4	5.6	MD-ACL-10-5-4T	5
	T012	8.0	MD-ACL-10-5-4T	5
Size E	T017	12.0	MD-ACL-15-3-4T	3
	T021	16.0	MD-ACL-40-1.45-4T	1.45
	T026	21.0	MD-ACL-40-1.45-4T	1.45

Dimensions

- Inovance input reactors

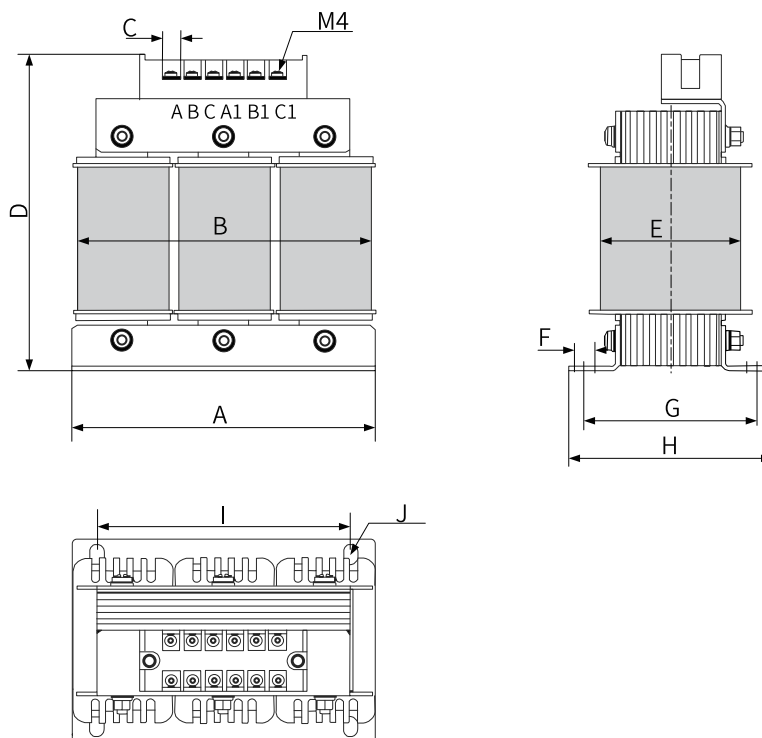

Figure 4-1 Dimensions of 10 A to 15 A AC input reactors

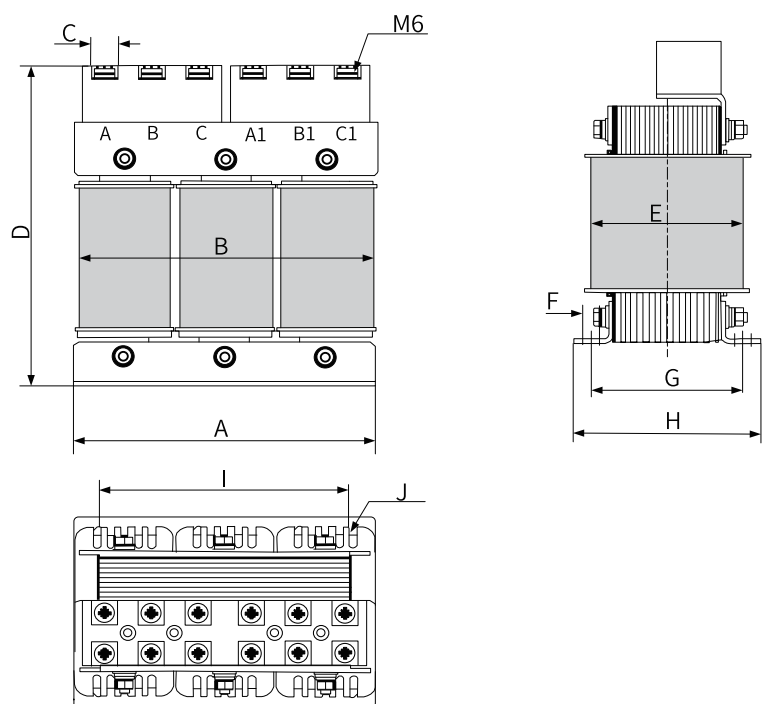

Figure 4-2 Dimensions of 40 A (1.45 mH) AC input reactors

Table 4-5 Dimensions of Inovance AC input reactors (unit: mm)

Model	A	B	C	D	E	F	G	H	I	J
MD-ACL-10-5-4T	150±2	155	8	160	80	10	85±2	100±2	125±1	Φ7 x 10
MD-ACL-15-3-4T	150±2	155	8	160	80	10	85±2	100±2	125±1	Φ7 x 10
MD-ACL-40-1.45-4T	180±2	185	16	200	105	10	95±2	117±2	150±1	Φ7 x 10

4.3.5 EMC filter

Model selection

To comply with EN IEC 61800-3 requirements in terms of radiated and conducted emission, install an EMC filter listed in the following table. EMC filter options are FN 2090 and FN 3287 series EMC filters manufactured by Schaffner. Select the EMC filter according to the rated input current of the servo drive, as shown in the following table.

Table 4-6 Standard EMC filter model and appearance



Filter Model		Appearance
Schaffner	FN 2090 series	
	FN 3287 series	

Table 4-7 Filter model selection (Schaffner)

Servo drive SV670N****I			Applicable Filter
Size	Model	Rated Input Current (A)	
Single-phase 220 V			
Size A	S1R6	2.3	FN 2090-3-06
	S2R8	4.0	FN 2090-4-06
Size C	S5R5	7.9	FN 2090-8-06
	S7R6	9.6	FN 2090-10-06
Size D	S012	12.8	FN 2090-16-06
Three-phase 220 V			
Size A	S1R6	1.1	FN 3287-10-44-C28-R65
	S2R8	1.8	FN 3287-10-44-C28-R65
Size C	S5R5	4.4	FN 3287-10-44-C28-R65
	S7R6	5.1	FN 3287-10-44-C28-R65
Size D	S012	8.0	FN 3287-10-44-C28-R65
Size E	S018	8.7	FN 3287-10-44-C28-R65
	S022	11.0	FN 3287-16-44-C33-R65
	S027	23.8	FN 3287-25-33-C33-R65
Three-phase 380 V			
Size C	T3R5	2.4	FN 3287-10-44-C28-R65
	T5R4	3.6	FN 3287-10-44-C28-R65

Servo drive SV670N****J			Applicable Filter
Size	Model	Rated Input Current (A)	
Size D	T8R4	5.6	FN 3287-10-44-C28-R65
	T012	8.0	FN 3287-10-44-C28-R65
Size E	T017	12.0	FN 3287-16-44-C33-R65
	T021	16.0	FN 3287-16-44-C33-R65
	T026	21.0	FN 3287-25-33-C33-R65

Dimensions

- Dimensions of Schaffner FN 2090 series filters

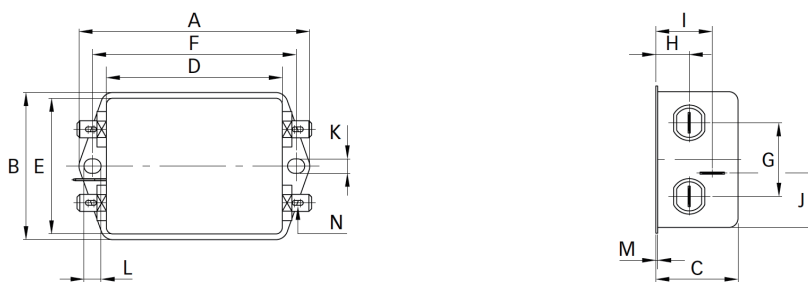

Figure 4-3 Dimensions of FN 2090 series filters (unit: mm)

Table 4-8 Dimensions of FN 2090 series filters (unit: mm)

Rated Current (A)	A	B	C	D	E	F	G	H	I	J	K	L	M	N
3	85	54	30.3	64.8	49.8	75	27	12.3	20.8	19.9	5.3	6.3	0.7	6.3x0.8
4														
6														
8	113.5±1	57.5±1	45.4±1	94±1	56	103	25	12.4	32.4	15.5	4.4	6	1	6.3x0.8

- Dimensions of Schaffner FN 3287 series filters

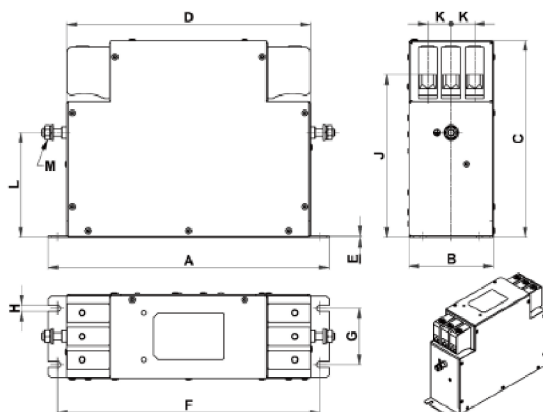

Figure 4-4 Dimension drawing of FN 3287 series filters (unit: mm)

Table 4-9 Dimensions of FN 3287 series filters (unit: mm)

Rated Current (A)	A	B	C	D	E	F	G	H	J±2	K	L±1	M
10	180	40	112	153	0.8	170	20	4.5	94	11	68	M5
16	200	45	112	170	0.8	185	25	5.4	102	11	76	M5
25	205	45	132	173	0.8	190	25	5.4	113	13	83	M5

4.3.6 Magnetic Ring and Magnetic Buckle

The magnetic ring is intended to be installed on the input or output side of the drive. Install the magnetic ring as close to the drive as possible. Installing the magnetic ring on the input side suppresses the noise in the input power supply system of the drive. Installing the magnetic ring on the output side reduces the bearing current and interference escaped to the outside.

In applications with leakage current and signal cable interference, install a magnetic ring or a ferrite clamp.

Model selection

- Amorphous magnetic ring: featuring a high permeability within 1 MHz and excellent anti-interference performance, but not as low-cost as the ferrite clamp. See for details. [“Dimensions” on page 81](#)
- Ferrite clamp: featuring a good interference suppression performance within a frequency band above 1MHz, applicable to low-power servo drives and signal cables, low-cost and easy to install

Magnetic ring and ferrite clamp		Appearance
Magnetic ring	DY644020H	
	DY805020H	
Ferrite clamp	7427122S	

Dimensions

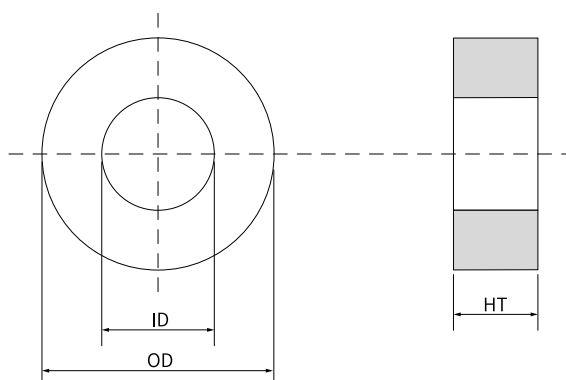

Figure 4-5 Dimension drawing of the magnetic ring

Table 4-10 Dimensions of the magnetic ring

Model	Size (OD×ID×HT) (mm)
DY644020H	64 × 40 × 20
DY805020H	80 × 50 × 20

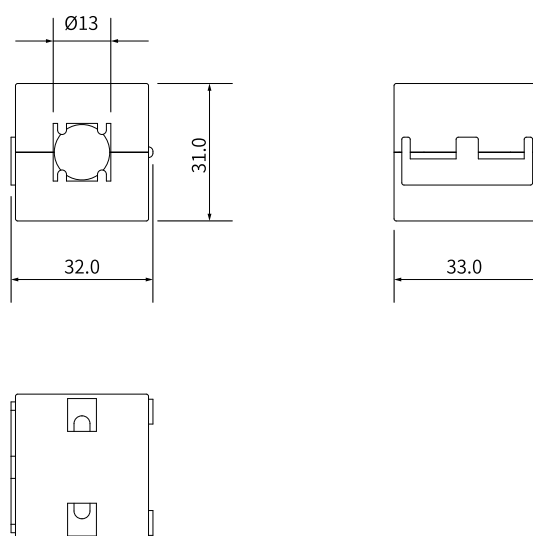

Figure 4-6 Dimension drawing of the ferrite clamp

Table 4-11 Specifications of the ferrite ring

Model	Size (Length × OD × ID) (mm)
7427122S	32.0 × 31 × 13

4.4 Absolute Encoder Batteries

Model selection

Select an appropriate battery according to the following table.

Table 4–12 Description of the absolute encoder battery

Battery Specifications	Item	Rated Values			Condition
		Min. Value	Typical Value	Max. Value	
Output: 3.6 V, 2500 mAh	External battery voltage (V)	3.2	3.6	5	In standby state ^[1]
	Circuit fault voltage (V)	-	2.6	-	In standby state
	Battery alarm voltage (V)	2.85	3	3.15	-
	Current consumed by the circuit (uA)	-	2	-	In normal operation ^[2]
		-	10	-	In standby state, shaft at standstill
		-	80	-	In standby state, shaft rotating
	Ambient temperature (°C)	0	-	40	Same as the motor.
Storage temperature (°C)	-20	-	60		

The preceding values are obtained under an ambient temperature of 20°C.

Note

- [1] The "standby state" means the encoder counts the multi-turn data by using the power from the external battery when the servo drive power supply is not switched on. In this case, data transeiving stops.
- [2] During normal operation, the absolute encoder supports one-turn or multi-turn data counting and transeiving. Power on the servo drive after connecting the absolute encoder properly. The encoder starts data transeiving after a short delay of about 5s upon power-on. The motor speed must be lower than or equal to 10 rpm during transition from the standby state to the normal operation state (upon power-on). Otherwise, Er.740 (Encoder fault) may occur. In this case, you need to power off and on the servo drive again.

Design life of the battery

The following calculation only covers the current consumed by the encoder.

Assume that the drive works normally for T1 in a day, the motor rotates for T2 after the drive is powered off, and the motor stops rotating for T3 after power-off [unit: hour (H)].

Example:

Table 4–13 Design life of the absolute encoder battery

Item	Schedule 1	Schedule 2
Working Days in Different Operating Conditions in 1 Year	313	52
T1 (h)	8	0
T2 (h)	0.1	0
T3 (h)	15.9	24

$$\text{Capacity consumed in 1 year} = (8 \text{ h} \times 2 \text{ uA} + 0.1 \text{ h} \times 80 \text{ uA} + 15.9 \text{ h} \times 10 \text{ uA}) \times 313 + (0 \text{ h} \times 2 \text{ uA} + 0 \text{ h} \times 80 \text{ uA} + 24 \text{ h} \times 10 \text{ uA}) \times 52 \approx 70 \text{ mAh}$$

$$\text{Design life} = \text{Battery capacity} \div \text{Capacity consumed in 1 year} = 2600 \text{ mAh} \div 70 \text{ mAh} = 37.1 \text{ years}$$

5 Compliance List

CE Certification

Command	Standard	
EMC directive 2014/30/EU	Servo drive	EN 61800-3
	Servo Motor	EN 61800-6-2
		EN 61800-6-4
		EN 55011
Low Voltage Directive 2014/35/EU	Servo drive	EN 61800-5-1
	Servo Motor	EN 60034-1 EN 60034-5
RoHS 2011/65/EU	Servo drive	EN 50581
	Servo Motor	

UL/cUL certification

Certification	Standard	
UL/cUL certification	Servo drive	UL61800-5-1
		C22.2 No.274-17
	Servo Motor	UL 1004-1
		UL 1004-6 CSA C22.2 No. 100-14

Note

The drive complies with the latest version of directives and standards for CE and UL/cUL certifications.

KC Certification

SV670 series servo drives are KC-certified.



19011851A03

Copyright © Shenzhen Inovance Technology Co., Ltd.

Shenzhen Inovance Technology Co., Ltd.

www.inovance.com

Add.: Inovance Headquarters Tower, High-tech Industrial Park,
Guanlan Street, Longhua New District, Shenzhen

Tel: (0755) 2979 9595

Fax: (0755) 2961 9897

Suzhou Inovance Technology Co., Ltd.

www.inovance.com

Add.: No. 16 Youxiang Road, Yuexi Town,
Wuzhong District, Suzhou 215104, P.R. China

Tel: (0512) 6637 6666

Fax: (0512) 6285 6720