



PS00005506A02

Easy521/ Easy522 Programmable Logic Controller User Guide

Suzhou Inovance Technology Co., Ltd.

Add.: No. 16 Youxiang Road, Yuexi Town,
Wuzhong District, Suzhou 215104, P.R. China
Tel: (0512) 6637 6666 Fax: (0512) 6285 6720
www.inovance.com



Preface

■ Introduction

The Easy521/Easy522/Easy523 series PLC, the new generation of small PLC developed by Inovance, supports network switchover through two network ports and allows process packaging and reuse through FB/FC function. With RS485, Ethernet, and EtherCAT, a multi-layer network communication can be realized through this PLC, with 16 modules extendable. RS485/RS232/CAN/DI/DO/AI/AO/RTC clock/TF card functions can also be available through the extension card.

This guide describes installation and wiring of the PLC, including product information, mechanical installation, and electrical installation.

■ Standards compliance

The following table lists the certifications, directives, and standards that the product may comply with. For details about the certifications compliant with, see the certification marks on the product nameplate.

Certification	Directive		Standards compliance
CE certification	EMC Directive	2014/30/EU	24 VDC products: EN 61131-2 220 VAC products: EN 61131-2 EN 61000-3-2 EN 61000-3-3
	Low Voltage Directive (LVD)	2014/35/EU	EN 61010-1 EN 61010-2-201
	RoHS Directive	2011/65/EU amended by (EU) 2015/863	EN IEC 63000
UL/cUL certification	-		UL 61010-1 UL 61010-2-201 UL 61010-2-030 CAN/CSA-C22.2 No. 61010-1 CSA C22.2 NO. 61010-2-201 CSA C22.2 NO. 61010-2-030

Certification	Directive	Standards compliance
KCC certification	-	-
EAC certification	-	-

More Documents

Document Name	Data Code	Description
GE20 Series Extension Card User Guide	PS00006443	Provides product information, installation and wiring, programming examples and for GE20 series extension card.

Revision history

Date	Version	Revision
March 2023	A02	Updated DIN rail mounting hook diagram and product specifications.
October 2022	A01	<ul style="list-style-type: none"> Added CAN communication function. Made minor corrections.
August 2022	A00	First release

Document acquisition

This guide is not delivered along with the product. You can download the PDF version in the following means:

- Log in to Inovance's website (www.inovance.com), choose Support > Download, search by keyword, and then download the PDF file.
- Scan the QR code on the product with your mobile phone.

Warranty

Inovance provides an 18-month warranty to the equipment from the date of shipment (subject to the barcode on the product) for failure or damage that occurs during normal use. If otherwise agreed upon, the agreed terms and conditions shall prevail. When the warranty period expires, reasonable maintenance fee will be charged.

The warranty does not cover any damage caused by:

- Operations not following instructions in the user guide
- Fire, flood, and abnormal voltage

- Unintended use
- Improper use outside the designed scope of application
- Force majeure (such as natural disaster, earthquake, and lightning strike) and the secondary damage caused thereof

The maintenance fee is charged according to the latest Maintenance Price List of Inovance. If otherwise agreed upon, the agreed terms and conditions shall prevail.

For details, see Product Warranty Card.

Fundamental Safety Instructions

■ Safety Disclaimer

- This chapter explains the safety precautions that need to be paid attention to when using this product correctly. Before operating the equipment, read through the guide and comprehend all the safety instructions. To ensure the safety of humans and equipment, follow the signs on the equipment and all the safety instructions in this user guide. Failure to comply may result in severe personal injuries or even death or equipment damage.
- The DANGER, WARNING and NOTICE messages in the user guide does not cover all the safety risks.
- Use this product in environments meeting the design and specification requirements; otherwise, a fault may occur. Noncompliance-caused malfunction or damage to parts are not covered in product quality warranty.
- Inovance shall take no responsibility for any personal injuries or property damage caused by improper usage.

■ Safety Levels and Definitions



Indicates that failure to comply with the notice can result in death or severe personal injuries.



Indicates that failure to comply with the notice may result in death or severe personal injuries.



Indicates that failure to comply with the notice may result in minor or moderate personal injuries or equipment damage.

■ Safety Precautions

- Product illustrations in the user guide are sometimes shown without covers or protective guards. Remember to install the covers or protective guards as specified first, and then perform operations in accordance with the instructions.
- Product illustrations in this guide are for reference only. Actual products may vary.

Unpacking

WARNING

- Do not install the equipment if you find any sign of damage, rust, or prior use on the equipment or accessories.
- Do not install the equipment if you find any sign of water seepage or missing or damaged components.
- Do not install the equipment if you find the packing list does not conform to the equipment you received.

CAUTION

- Check whether the packing is intact and whether there is any sign of damage, water seepage, dampness, and deformation.
- Unpack the package by following the unpacking sequence. Do not strike the package violently.
- Check whether there is any sign of damage or rust on the surfaces of the equipment and accessories.
- Check whether the package contents are consistent with the packing list.

Storage and transportation

CAUTION

- Handle the equipment with care during transportation and mind your steps to prevent personal injuries or equipment damage.
- When carrying the equipment with bare hands, hold the equipment casing firmly with care to prevent parts from falling. Failure to comply may result in personal injuries.
- Store and transport this product in strict accordance with the storage and transportation requirements. Failure to comply may result in damage to the product.
- Do not store or transport the equipment in environments exposed to water splash, rain, direct sunlight, strong electric field, strong magnetic field, and strong vibration.
- Avoid storing this product for more than three months. Long-term storage requires stricter protection and necessary inspections.
- Pack the equipment strictly before transportation. Use a sealed box for long-distance transportation.
- Never transport the equipment with other equipment or materials that may harm or have negative impacts on this equipment.

Installation



- Installation must be carried out by the specialists who have received the necessary electrical training and understood enough electrical knowledge. Ensure no unprofessional person has access to the equipment.



- Read through the guide and safety instructions before installation.
- Do not install this equipment in places with strong electric or magnetic fields.
- Before installation, ensure that the installation position has sufficient mechanical strength to support the weight of the device. Failure to comply will result in a mechanical danger.
- To avoid electric shock, do not wear loose clothes or accessories.
- When this equipment is installed in a cabinet or final equipment, use a cooling device (such as a fan or air conditioner) to cool the environment down to the required temperature. Failure to comply may result in equipment over-temperature or a fire.
- Do not retrofit this equipment.
- Do not fiddle with the bolts used to fix equipment components or the bolts marked in red.
- When this product is installed in a cabinet or terminal device, protection measures such as a fireproof enclosure, an electrical enclosure, or a mechanical enclosure must be provided. The IP rating must meet IEC standards and local laws and regulations.
- Before installing devices with strong electromagnetic interference, such as a transformer, install a shielding device for the equipment to prevent malfunction.
- Install the equipment onto flame retardant materials, such as metal. Keep the equipment away from combustible objects. Failure to comply will result in a fire.

CAUTION

- During installation, use a piece of cloth or paper to cover the top of the product to prevent metal chippings, oil, and water from entering into the product when drilling holes. Failure to comply will cause product malfunctions. After installation, remove the cloth or paper for effective ventilation and cooling.
- If the device running at a constant speed begins to run at variable speeds, resonance may occur. In this case, install the vibration-proof rubber under the motor frame or use the vibration suppression function to reduce resonance.

Wiring

DANGER

- Only professionals are allowed to perform installation, wiring, maintenance, inspection or parts replacement on the equipment.
- Before wiring, cut off all the power supplies of the equipment. Wait as specified on the product warning sign before further operations because residual voltage exists after power-off. Measure the DC voltage of the main circuit and make sure that it is below the safety voltage. Failure to comply will result in an electric shock.
- Never perform wiring, remove the product cover, or contact the PCB at power-on. Failure to comply will result in an electric shock.
- Check that the equipment is grounded properly. Failure to comply will result in an electric shock. Separate grounding or single-point grounding, other than common grounding, is recommended.

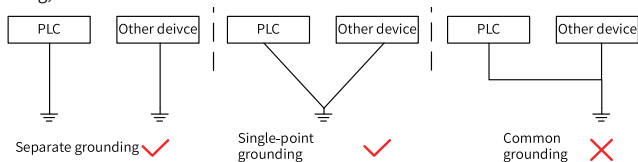

 **WARNING**

- Do not connect the input power supply to the output end of the equipment. Failure to comply can result in equipment damage or even a fire.
- When connecting a drive to the motor, make sure the phase sequence of the drive and motor are consistent to prevent motor reverse rotation.
- Cables used for wiring must meet cross sectional area and shielding requirements. The shield of the cable must be reliably grounded at one end.
- Ensure that all cables are connected correctly. Cable sheath is not damaged, and no screw or washer is left inside the equipment. Otherwise, electric shock or equipment damage may occur.

 **CAUTION**

- During wiring, follow the proper electrostatic discharge (ESD) procedure and wear an antistatic wrist strap. Failure to comply can result in damage to the equipment or internal circuits.
- In wiring the control circuit, use shielded twisted pair cable and connect the shield to the PE terminal. Otherwise, the equipment may not function properly.

Power-on **DANGER**

- Before power-on, check that the equipment is installed properly, the wiring is secure and the motor can be restarted.
- Before power-on, check that the power supply meets equipment requirements to prevent equipment damage or even a fire.
- After power-on, do not open the cabinet door or protective cover of the equipment. Do not touch any wiring terminals, or remove any part of the equipment at power-on. Failure to comply will result in an electric shock.

 **WARNING**

- Perform a trial run after wiring and parameter setting to ensure that the equipment operates safely. Failure to comply may result in personal injuries or equipment damage.
- Before power-on, ensure that the nominal voltage of the equipment is consistent with the power supply voltage. Improper power supply voltage will cause a fire.
- Before power-on, ensure that there are no people around the equipment, motor and other machines. Failure to comply will result in injuries or death.

Operation **DANGER**

- Only qualified professionals are allowed to run the equipment. Failure to comply can result in injury or death.
- Do not touch any wiring terminals or remove any part of the equipment during operation. Failure to comply will result in an electric shock.

 **WARNING**

- Do not touch the equipment enclosure, fan, or resistor to sense the temperature. Failure to comply may result in burns.
- Prevent metal or other objects from falling into the device during operation. Failure to comply may result in a fire or product damage.

Maintenance **DANGER**

- Only professionals are allowed to perform installation, wiring, maintenance, inspection or parts replacement on the equipment.
- Do not perform maintenance on the equipment with power ON. Failure to comply can result in the risk of electric shock.
- Before maintenance, cut off all power supplies of the device and wait for a period specified on the warning label of the device.
- When a PM motor rotates, its terminals will produce induced voltage even if the motor is powered off. Failure to comply will result in an electric shock.

 **WARNING**

- Perform routine and periodic inspection and maintenance on the equipment according to maintenance requirements and keep a maintenance record.

Repair **DANGER**

- Only professionals are allowed to perform installation, wiring, maintenance, inspection or parts replacement on the equipment.
- Do not repair the equipment after power-on. Failure to comply can result in the risk of electric shock.
- Before device inspection and repair, cut off all power supplies of the device and wait for a period specified on the warning label of the device.

 **WARNING**

- Submit the repair request according to the warranty agreement.
- When the fuse is blown, the circuit breaker trips, or the earth leakage circuit breaker (ELCB) trips, wait for a period specified on the warning label of the device before you energize or operate the device. Failure to comply may result in personnel injuries or damage to the device.
- When the device is faulty or damaged, require professionals to perform troubleshooting and repair by following repair instructions and keep a repair record.
- Replace quick-wear parts of the equipment according to the replacement instructions.
- Do not operate damaged device. Failure to comply may result in personnel injuries or death or greater damage to the device.
- After replacing the equipment, perform wiring inspection and parameter settings again.

Disposal **WARNING**

- Dispose of retired equipment in accordance with local regulations and standards. Failure to comply may result in property damage, personal injuries, or even death.
- Recycle retired equipment by observing industry waste disposal standards to avoid environmental pollution.

■ Safety labels

To ensure safe operations, comply with safety signs on the device, and do not damage or remove the safety labels. See the following table for descriptions of the safety labels.

Safety Label	Description
	<ul style="list-style-type: none">• Read through the safety instructions before operating the equipment. Failure to comply may result in death, personal injuries, or equipment damage.

1 Product Information

1.1 Model and Nameplate

■ Model

Easy 52X – 0808 TN

①

②

③

④

① Product series Easy: Easy series programmable logic controller	③ Inputs/Outputs 08: 8 inputs 08: 8 outputs
② Series No. X stands for 1, 2, 3, i.e. 521, 522, 523 5: With EtherCAT 2: Two Ethernet interfaces 1/2/3: 8-axis/16-axis/32-axis	④ Output type TN: SINK transistor

■ Nameplate

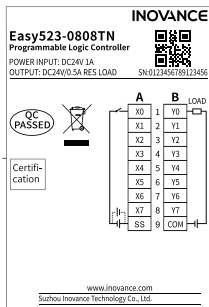
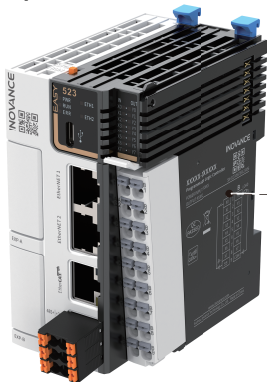

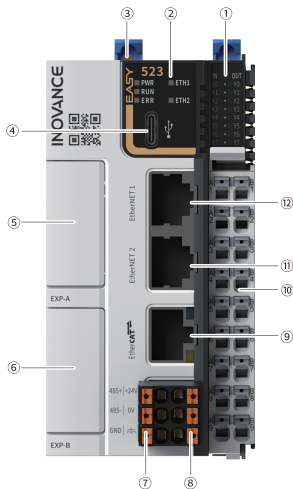

Model	Description	Code
Easy521-0808TN	Easy500 series 8-axis programmable controller with 8 inputs and 8 outputs	01440385
Easy522-0808TN	Easy500 series 16-axis programmable controller with 8 inputs and 8 outputs	01440383
Easy523-0808TN	Easy500 series 32-axis programmable controller with 8 inputs and 8 outputs	01440326

1.2 Components



No.	Terminal type	Terminal code	Assignment	Indicator color	Description
①	I/O indicator	IN/OUT	I/O status display	Yellow-green	<ul style="list-style-type: none"> • Solid ON: Indicates the input or output is active. • OFF: Indicates the input or output is inactive.

No.	Terminal type	Terminal code	Assignment	Indicator color	Description
②	Operation status indicator	PWR	Power supply	Yellow-green	<ul style="list-style-type: none"> ● Solid ON: Indicates that the power supply is normal. ● OFF: Indicates that the power supply is abnormal.
		RUN	Operation	Yellow-green	<ul style="list-style-type: none"> ● Solid ON: Indicates that the user program is running. ● OFF: Indicates that the user program has been stopped.
		ERR	Operation error	Red	<ul style="list-style-type: none"> ● OFF: Indicates no critical errors occur. ● Flashing: Indicates a critical error has occurred.
		ETH1	EtherNET1 Link	Yellow-green	<ul style="list-style-type: none"> ● Solid ON: Indicates that the link has been established. ● Flashing: Indicates communication is in progress. ● OFF: Indicates that the link is not established.
		ETH2	EtherNET2 Link	Yellow-green	<ul style="list-style-type: none"> ● Solid ON: Indicates that the link has been established. ● Flashing: Indicates communication is in progress. ● OFF: Indicates that the link is not established.

No.	Terminal type	Terminal code	Assignment	Indicator color	Description
③	DIP switch	RUN/STOP	Used to control the operation of the master.	-	-
④	Type-C interface		Used for communication with PC.	-	-
⑤/- ⑥	Extension card slot	01/02	Used for function extension.	-	For details of extension card options, see " Appendix: Extension Card Options " on page 41.
⑦	RS485	485+	RS485 communication signal+	-	-
		485-	RS485 communication signal-	-	-
		GND	RS485 communication GND	-	-
⑧	Power supply interface	+24V	24 VDC power supply (+)	-	-
		0V	24 VDC power supply (-)	-	-
			PE	-	-
⑨	EtherCAT interface	EtherCAT	Used for EtherCAT communication.	-	-
⑩	I/O terminal	-	8 inputs and 8 outputs	-	See details in " 3.1 Layout of Terminals " on page 30.
⑪/- ⑫	Ethernet port	EtherNET1/ EtherNET2	Ethernet RJ45 interface	-	-

1.3 Product Specifications

1.3.1 General Specifications

Item	Easy521-0808TN	Easy522-0808TN	Easy523-0808TN
Program data capacity	200 k-step user program 2 Mb user-defined variables, in which 128 kb variables are retentive at power failure; About 150 k soft elements (Elements after No. 1000 are retentive at power failure.)		
Reference speed	20 k-step user program executed in 1.6 ms		
Bit operation	0.113 μ s/instruction		
Word transmission	0.232 μ s/instruction		
Float operation	0.578 μ s/instruction		
Ethernet	Supports Ethernet/IP, ModbusTCP, Socket, program download/upload, and firmware upgrade.		
EtherCAT communication	Supports 1 EtherCAT master with up to 72 EtherCAT slaves.		
Number of axes available (pulse + bus)	8-axis	16-axis	32-axis
Serial communication	Supports up to 3 channels (one channel in the main unit and two channels extended in the extension card).		
CAN communication	Supports 1 master through the extension card (firmware version 5.66.0.0 and later, software version AutoShop4.8.0.0 and later). <ul style="list-style-type: none">● CANlink: Supports up to 63 slaves.● CANopen Supports up to 30 slaves.		
High-speed input	Single-phase: 8-channel 200 k		
High-speed output	5-axis 200 k, PWM pulse width modulation supported		
Extension module	Supports up to 16 local extension modules.		
Extension card	Supports up to two extension cards.		
Program language	LD, SFC, FB/FC function (LD) supported		

Item	Easy521-0808TN	Easy522-0808TN	Easy523-0808TN
Type-C	Supports user program download/upload and firmware upgrade through GE20–TF extension card.		
IP rating	IP20		
Dimensions (W x H x D)	53 mm x 100 mm x 80 mm		
Weight	About 197 g		

1.3.2 Power Supply Specifications

Item	Specifications
Rated voltage of terminal input power supply	24 VDC \pm 10% (21.6 VDC to 26.4 VDC)
Rated current of terminal input power supply	1 A (max. value at 24 VDC)
24 V input power supply protection	Providing protection against short circuit and reverse connection
Hot-plugging	Not supported

1.3.3 Input Specifications

Item	Specifications	
Input type	Digital input	
Number of input channels	8	
Input mode	SINK/SOURCE	
Input voltage class	24 VDC \pm 10% (21.6 VDC to 26.4 VDC)	
High-speed input (X0–X7)	Input current at input ON	> 4 mA
	Input current at input OFF	< 2.5 mA
	Hardware response time	2 μ s (RC time)
	Max. input frequency	200 kHz
	Input impedance	3.4 k
ON voltage	\geq 15 VDC	
OFF voltage	\leq 5 VDC	

Item	Specifications
Software filter time	<ul style="list-style-type: none"> • Low-speed: 2 ms to 1000 ms • High speed: 2 μs to 1000 μs
Isolation mode	Isolated by digital isolator chip
Common terminal mode	8-point/common terminal (The polarity +/- of input power supply is changeable.)
Input action display	The input indicator lights up (controlled by software) when the input is in drive state.

1.3.4 Output Specifications

Item	Specifications	
Output type	Transistor NPN	
Number of output channels	8	
Output voltage class	24 VDC \pm 10% (21.6 VDC to 26.4 VDC)	
High-speed output (Y0 to Y7)	Output load (resistive load)	0.5 A/point; 2 A/8-point
	Output load (inductive load)	7.2 W/point; 24 W/8-point
	Output load (lamp load)	5 W/point, 18 W/8-point
	Hardware response time ON/OFF	< 1 μ s (OFF \rightarrow ON); < 2 μ s (ON \rightarrow OFF)
	Load current requirements	Load current \geq 12 mA when used with outputs greater than 10 kHz
	Max. output frequency	200 kHz for resistive load; 0.5 Hz for inductive load; 10 Hz for lamp load
Leakage current at OFF	Less than 30 μ A at 24 V	
Max. residual voltage during ON	Less than 0.5 VDC	
Isolation mode	Digital isolator	
Common terminal mode	8-point/common terminal ("- of power supply)	

Item	Specifications
Short circuit protection	Providing protection against short circuit of each circuit (The short circuit protection state can be cancelled through a power cycle.)
External inductive load protection	Connect a flywheel diode ^[1] when connecting the external inductive load.
Output action display	The output indicator lights up (controlled by software) when the output is in drive state.

[1]: D: 1N4001 or similar diodes are shown in the following figure.

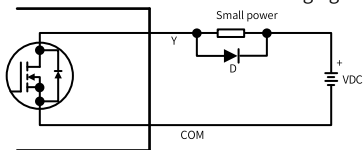

2 Mechanical Installation

2.1 Installation Environment

Take the operability, serviceability, and adaptability to environment into account when installing the PLC.

Item	Specification
Working environment	Free from corrosive gas and flammable gas, as well as excessive conductive dust
Altitude	Up to 2000 m (80 kPa)
Pollution degree	PD2
Immunity	2 kV on the power supply line (IEC 61000-4-4)
Overvoltage category	I
EMC immunity level	Zone B, IEC61131-2
Vibration resistance	IEC 60068-2-6, 5 Hz to 8.4 Hz, 3.5 mm, 8.4 Hz to 150 Hz, 1 g, 10 cycles in each of X, Y and Z directions
Shock resistance	IEC 60068-2-27 150 m/s ² , 11 ms, 3 times in each of $\pm X$, $\pm Y$ and $\pm Z$ directions, 18 times in total
Overcurrent protection device	1.1 A fuse
Storage temperature and humidity range	<ul style="list-style-type: none">● Storage temperature: -20 °C to +60 °C● Relative humidity: < 90% RH (without condensation)
Shipping temperature/humidity	<ul style="list-style-type: none">● Shipping temperature: -40 °C to +70 °C● Relative humidity: < 95% RH (without condensation)

Item	Specification
Operating temperature/ humidity	<ul style="list-style-type: none"> ● Operating temperature: -20 °C to +55 °C (horizontally), -20 °C to +45 °C (non-horizontally) ● Relative humidity: < 95% RH (without condensation) <p>Note: Install a fan or air conditioner in the direction of the cooling hole when the operating temperature is greater than the maximum temperature.</p>

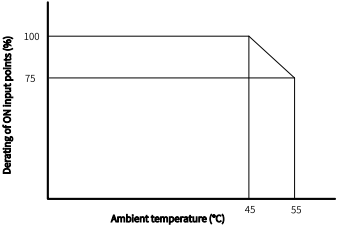
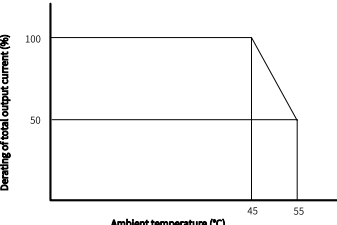
Item	Specification
<p>Installation position and limit</p>	<p>Installation position: The PLC can be installed in four directions as shown in "2.2 Installation Position" on page 24.</p> <p>Limit:</p> <ul style="list-style-type: none"> ● When installed horizontally: <ul style="list-style-type: none"> ■ Input derating: The PLC can operate with full load at ambient temperature of 45°C. Derate the number of ON input points to 75% (lower than or equal to six ON input points) at ambient temperature of 55°C. Derate the number of ON input points by 2.5% for every additional 1°C above 45°C.  <ul style="list-style-type: none"> ■ Output derating: The PLC can operate with full load (total current of eight output points not exceeding 2 A) at ambient temperature of 45°C. Derate the total output current of ON output points to 50% (total current of eight output points not exceeding 1 A) at ambient temperature of 55°C. Derate the total output current of ON output points by 5% for every additional 1°C above 45°C.  ● When installed non-horizontally: The maximum number of input points connected cannot exceed six, the maximum output current cannot exceed 1 A, and the number of modules cannot exceed six.

2.2 Installation Position

This product can be installed in four positions (namely four installation directions): Horizontally, vertically, and top or bottom of the cabinet. It is recommended to install the PLC horizontally. Different installation positions require different operating temperatures and limits. For details, see ["2.1 Installation Environment" on page 21](#).

■ Optimal installation position

It is recommended to install the PLC horizontally, with natural convection as the cooling mode. To ensure normal heat dissipation and sufficient wiring space, reserve minimum clearance around the PLC, as shown below.

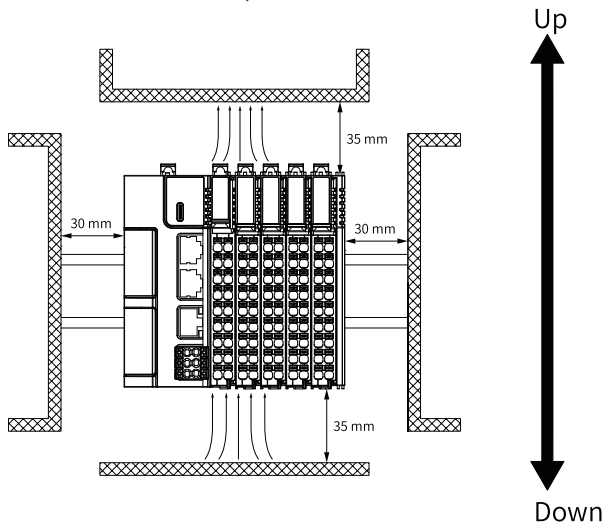

Note

Keep the PLC away from high-temperature heating sources (heater, transformer, large resistor, etc.) by at least 100 mm.

■ Other installation positions

The surrounding clearance required on other installation positions are the same as the optimal one. Other installation positions are shown in the diagram below.

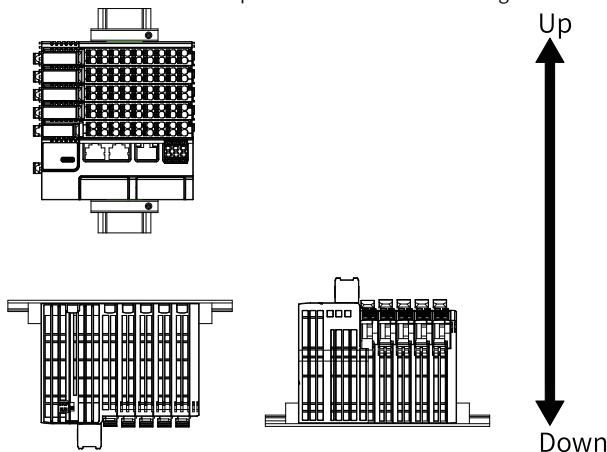

Caution

In case of vertical installation:

- Install the PLC below all I/O modules.
- Hold the cables with a cable duct to prevent the weight of cables being applied to the lower end plate. Failure to comply may cause displacement of the PLC from the DIN rail, leading to maloperation of the PLC.

2.3 Installation Precaution

- Before installing or removing the master and module, ensure that the master and module are powered off.



Caution

Do not connect/disconnect the module with power ON. This may lead to master restart or user data loss or damage.

- Prevent the master, module enclosure, or terminals from dropping or suffering from impact or shock.

2.4 Installation Dimensions

The installation dimensions (in mm) are shown in the figure below.

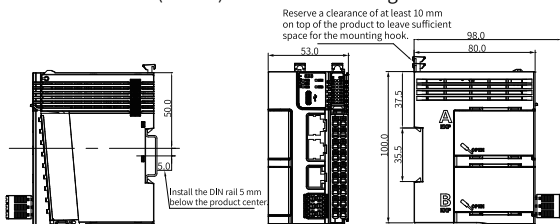

2.5 Installation Methods

The module is mounted onto a DIN rail that complies with IEC 60715 (width: 35 mm, thickness: 1 mm). The dimensions (unit: mm) are shown below.

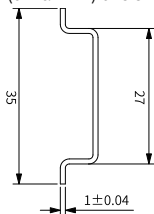



Caution

When installed on a DIN rail other than the recommended one (especially the one whose thickness is not 1.0 mm), the module will not fit in place as the mounting hook does not work.

■ Installing the master

1. Align the module with the DIN rail and push the module in the direction indicated by the arrow until you hear a clicking sound, as shown below.

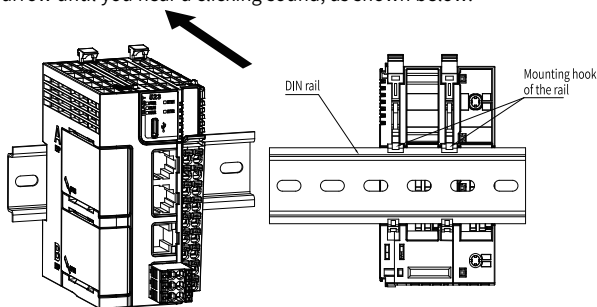

2. Make sure the DIN rail mounting hook of the module is locked. The locked and unlocked states of the mounting hook are shown below.



- If the mounting hook is pressed down, it is locked.
- If the mounting hook is lifted up, it is unlocked.

When the mounting lock is unlocked, press it down to lock the module to the DIN rail.



Keep the mounting hook locked when the controller is not mounted on the rail. If the mounting hook is kept unlocked for an extended period of time, it may malfunction.

■ Installing the module to the master

Install the extension module to the master through top and bottom rails, as shown below.

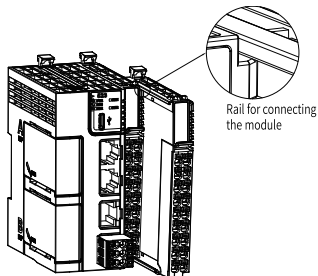

Install a DIN rail end plate to both sides of the master or module. To mount the end plate, hook the bottom of it to the bottom of the DIN rail, rotate the end plate to hook the top of it to the top of the DIN rail, and then tighten the screw to lock the end plate in place, as shown below.

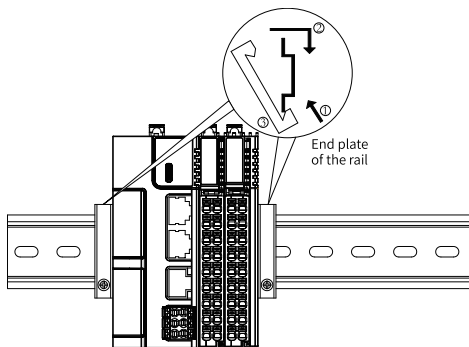

■ Removing the module

Pry the mounting hook upwards with a tool such as a straight screwdriver or similar, and pull out the module forwardly. Then press down the top of the mounting hook.

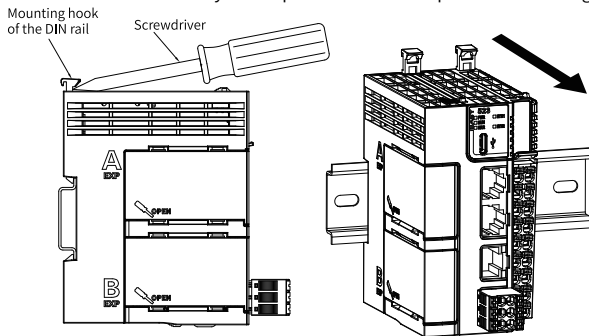

3 Electrical Installation

3.1 Layout of Terminals



Signals on the left	Terminals on the left	Terminals on the right	Signals on the right
X0 input	1A	1B	Y0 output
X1 input	2A	2B	Y1 output
X2 input	3A	3B	Y2 output
X3 input	4A	4B	Y3 output
X4 input	5A	5B	Y4 output
X5 input	6A	6B	Y5 output
X6 input	7A	7B	Y6 output
X7 input	8A	8B	Y7 output
Common terminal of input	9A	9B	Common terminal of output



Caution

- The length of a high-speed I/O interface extension cable must be within 3.0 m.
- To prevent interference, route the I/O interface extension cable and the power cable (high-voltage/high-current cables) through different non-parallel routes.

3.2 Wiring of Input Terminals

■ SINK input wiring

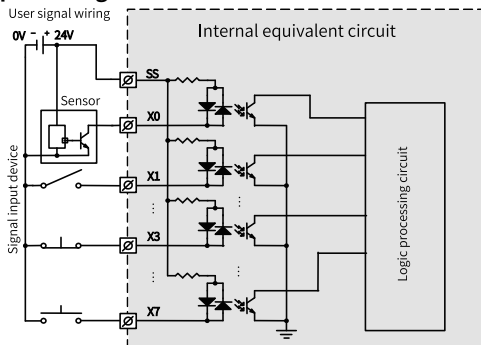

■ SOURCE input wiring

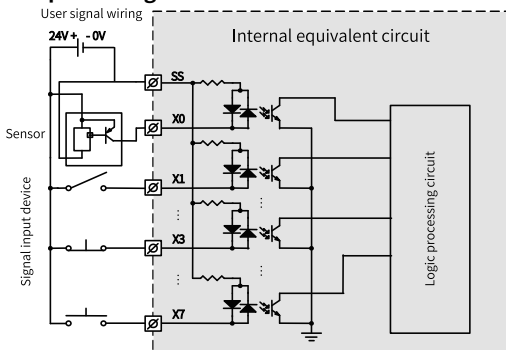

3.3 Wiring of Output Terminals

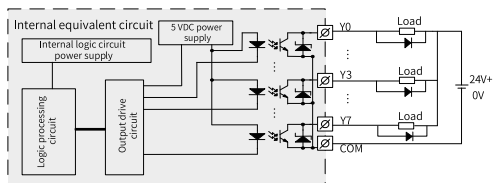

Note

Connect a flywheel diode when connecting the external inductive load. Diodes can be 1N4001 or similar.

4 Communication Connection

4.1 Networking

This PLC can be connected to other sites, ERP, MES and other systems through Ethernet interface, or connected to other slaves (such as MD520, MD800, SV630N and SV660N drives) or other modules with EtherCAT function through EtherCAT interface. With GE20 series extension cards, this PLC can also be connected to H5U, SV630C, and IR311 series industrial robots through RS485, RS232, or CAN communication, as shown below.

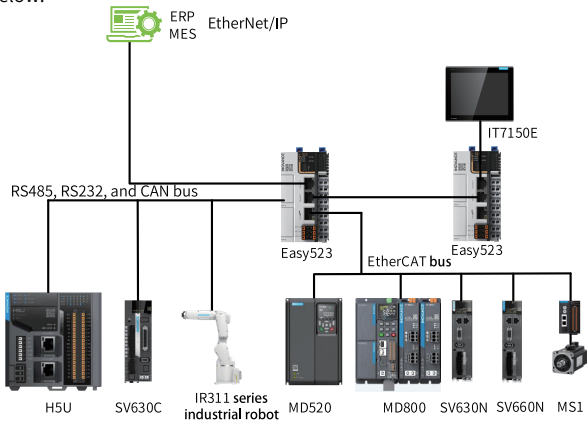

4.2 Cable Selection

The cable lug and cross sectional area of the cable listed in the following table are for reference only.

Material name	Applicable cross sectional area		KST		Suzhou Yuanli	
	GB/mm ²	AWG	Model	Crimping tool	Model	Crimping tool
Tubular lug	0.3	22	E0308	KST2000L	0308	YAC-5
	0.5	20	E0508		0508	
	0.75	18	E7508		7508	
	1.0	18	E1008		1008	
	1.5	16	E1508		1508	

If you use other types of tubular lug, crimp the lug to the twisted pair as shown below.

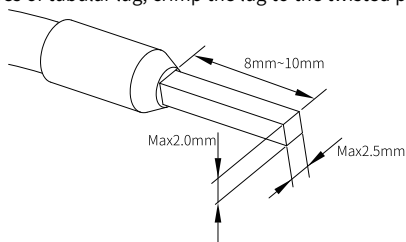

4.3 Cable Connection

■ RS485 communication

The RS485 communication port and power supply port share the same terminal block, with RS485 communication port on the left and 24 V power supply port on the right.

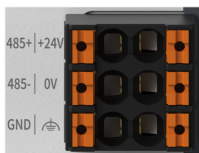

- Assignment

Description	Terminals on the left	Terminals on the right	Description
RS485 differential pair (+)	485+	+24V	24 VDC power supply (+)
RS485 differential pair (-)	485-	0V	24 VDC power supply (-)
Communication grounding terminal of RS485	GND		PE

- Communication specifications

Item	Description
Number of channels supported	Three channels at most (one built-in and two extended in the extension card, including RS232)
Hardware interface	2 x 3-pin terminal (shared with the power supply)
Isolation mode	Non-isolated
Termination resistor	Without termination resistor, can be master or slave
Number of slaves connected	Up to 31 slaves (The length of each slave branch must be shorter than 3 m.)
Communication baud rate	9600 bit/s, 19200 bit/s, 38400 bit/s, 57600 bit/s, and 115200 bit/s
Short circuit protection	Providing protection against improper connection of 24 V power supply

- Wiring

See ["4.2 Cable Selection" on page 33](#) when selecting the communication cable, Insert the communication cable into the communication port.

■ Ethernet communication

To improve communication reliability, use Cat 5e cables with injection molded and iron shell as Ethernet cables.

- Connection: Insert the registered jack on the cable into the Ethernet port (RJ45 interface) until hearing a clicking sound.

- Disconnection: Pull out the connector by pressing the tail of the registered jack.

4.4 EtherCAT Communication Description

■ EtherCAT Specifications

Item	Description
Communication protocol	EtherCAT Protocol
Available services	CoE (PDO, SDO)
Synchronization mode	Distributed clock for the drive and synchronous input/output for I/O
Physical layer	100BASE-TX
Baud rate	100 Mbit/s (100Base-TX)
Duplex mode	Full duplex
Topology	Linear topology
Transmission medium	Network cable
Transmission distance	Less than 100 m between two nodes
Number of slaves	Up to 72 slaves
EtherCAT Frame length	44 to 1498 bytes
Process data	1486 bytes at most for an individual Ethernet frame

■ Wiring

The PLC achieves EtherCAT bus communication through CN3, which requires the following communication cable:

Communication cable requirements

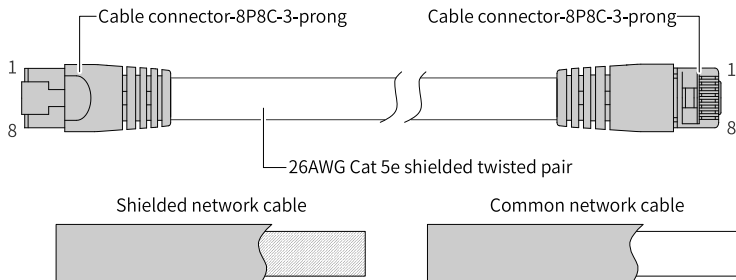

Signal pin assignment

Pin	Signal	Signal direction	Description
1	TD+	Output	Data transmission+
2	TD-	Output	Data transmission-
3	RD+	Input	Receive data (+)
4	-	-	Not used
5	-	-	Not used
6	RD-	Input	Receive data (-)
7	-	-	Not used
08	-	-	Not used

Length requirement

The cable between devices cannot exceed 100 m when the EtherCAT bus is used, exceeding of which may attenuate the signal and affect normal communication.

Technical requirements:

Short circuit, open circuit, misalignment, or poor contact does not occur during 100% continuity test. Cables compliant with the following specifications are recommended.

Item	Specification
Cable type	Flexible crossover cable, S-FTP, Cat5e
Standards compliance	EIA/TIA568A, EN50173, ISO/IEC11801 EIA/TI Abulletin TSB EIA/TIA SB40-A&TSB36

Item	Specification
Cross sectional area of the cable	26AWG
Cable category	Twisted pair
Number of pairs	4

4.5 RS485 Communication Instructions

It is recommended to use a shielded twisted pair cable as the RS485 bus. Connect a 120 Ω termination resistor to both ends of the bus respectively to prevent signal reflection. Connect the signal reference grounds of all nodes together. Up to 31 nodes can be connected and the distance between nodes must be less than 3 m.

The RS485 bus topology is shown in the figure below.

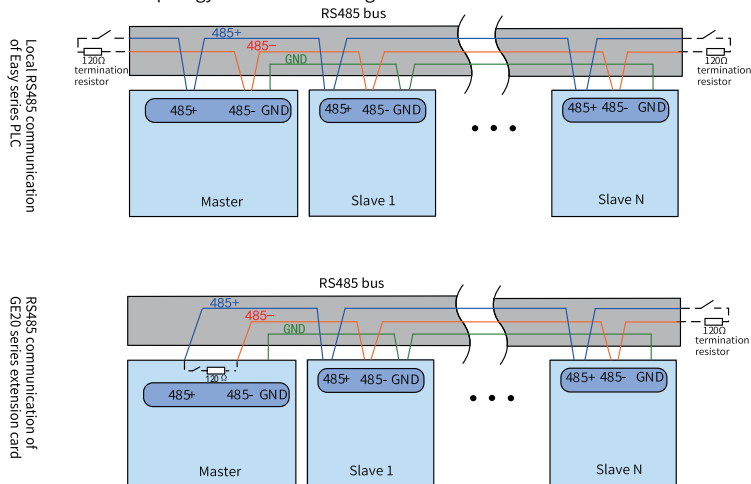

5 Operation and Maintenance

5.1 Start and Stop

After the PLC is programmed, start and stop it as follows.

To run the PLC:

1. Set the system to RUN.
2. Check that the RUN indicator is solid on in yellow-green.
3. To stop the PLC, set the system to STOP state. Alternatively, you can stop it in the software tool of the host controller.

5.2 Programming of SD Card User Programs

1. Save the SD card programming file compiled by Autosshop to the directory "PLCProgram" of the SD card (maximum capacity 32 GB, file formate FAT32).
2. Load the SD card onto the TF extension card and install the card to the PLC.



Caution

Install the TF extension card with power off.

3. Power on the PLC again and start programming the user programs in the SD card to the PLC. The RUN indicator flashes at a frequency of 4 Hz during programming.
4. After programming is done, the RUN indicator flashes at a frequency of 1 Hz and this PLC enters the STOP state. You can remove the SD card now.

If the ERR indicator flashes slowly, programming fails. Check that the model of the programming file is consistent with the actual model and the login password of the programming file is the same as that of the PLC. If the model and password are both correct but the programming failure still occurs, contact Inovance for technical support.

5. Power off and on again.

5.3 SD Card Firmware Upgrade

1. Load the SD card (maximum capacity 32 GB, file format FAT32) to the TF extension card and the PLC.
-



Caution

Install the TF extension card with power off.

2. Power on the PLC again.

The RUN and ERR indicators flash quickly for 3s, indicating that the firmware upgrade begins. The RUN and ERR indicators remain solid ON, indicating that the firmware is being upgraded. The RUN and ERR indicators flash slowly, indicating that the firmware upgrade is done.

3. After firmware upgrade is done, power off the PLC and remove the SD card.
4. Power on the PLC again.

Appendix: Extension Card Options

Model	Type	Description	Slot	ID
GE20-4DI	Digital input/ output	4 inputs 24 VDC input Source/Sink	A/B	13
GE20-4DO-TN		4 transistor sink outputs 24 VDC output	A/B	5
GE20-2AD1DA-I	Analog input/ output	2 analog inputs and 1 analog output (current type)	A/B	11
GE20-2AD1DA-V		2 analog inputs and 1 analog output (voltage type)	A/B	3
GE20-CAN-485	Communication extension	CAN and 485 communication (RJ45 interface)	A	15
GE20-232/485		RS232 or RS485 communication	A/B	7
GE20-232/ 485-RTC		RS232 or RS485 communication (with RTC)	B	14
GE20-TF	Storage extension	TF extension card	B	1
GE20-RTC	Clock extension	Clock extension card	B	9

Note

The ID is "0" when there is no extension card.